

Let's set up your 5 seat sofa + arm/back

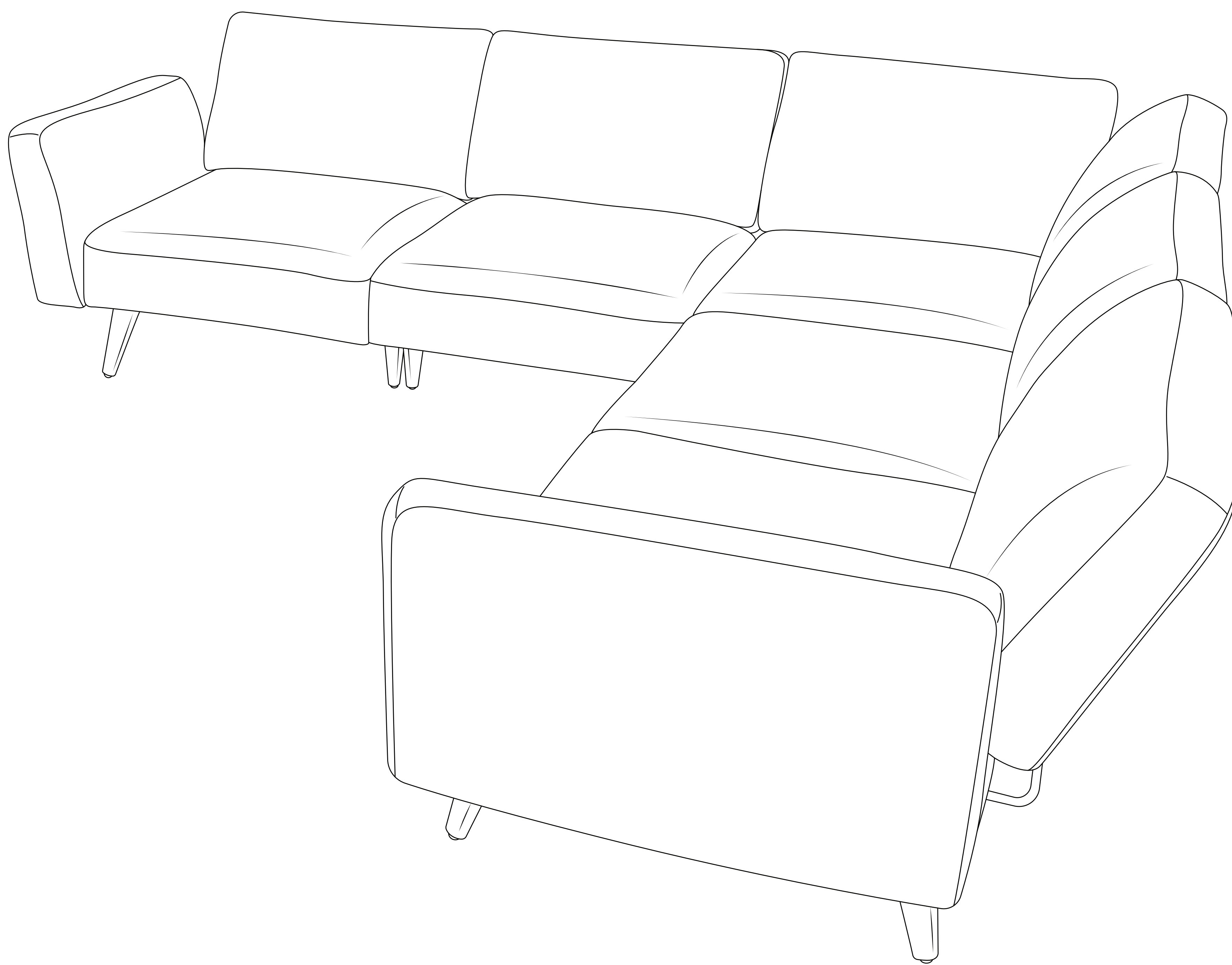

**1** Unbox seats and align the holes

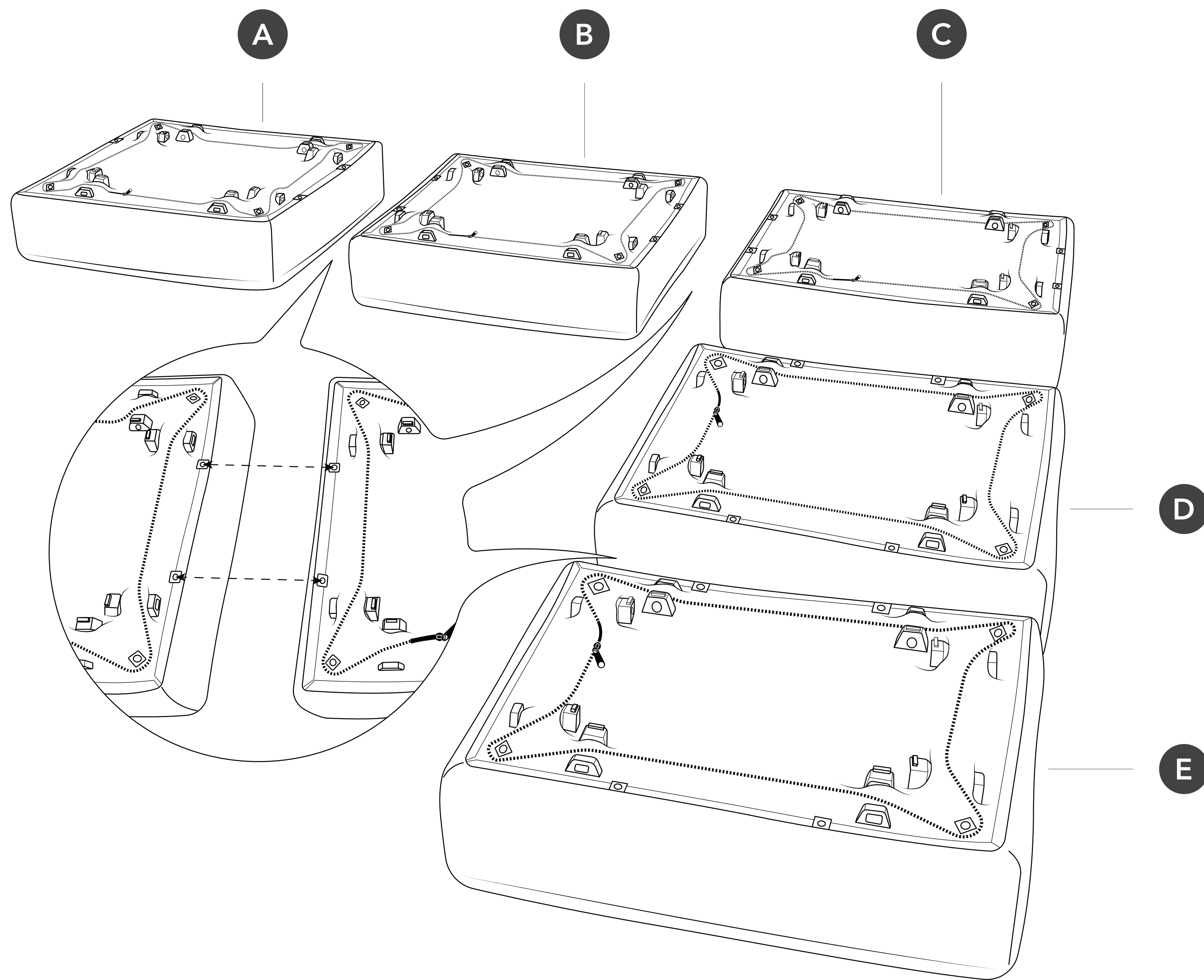

**2** Remove legs and brackets  
Unzip pocket underneath the seat and remove the legs, felt pads and brackets

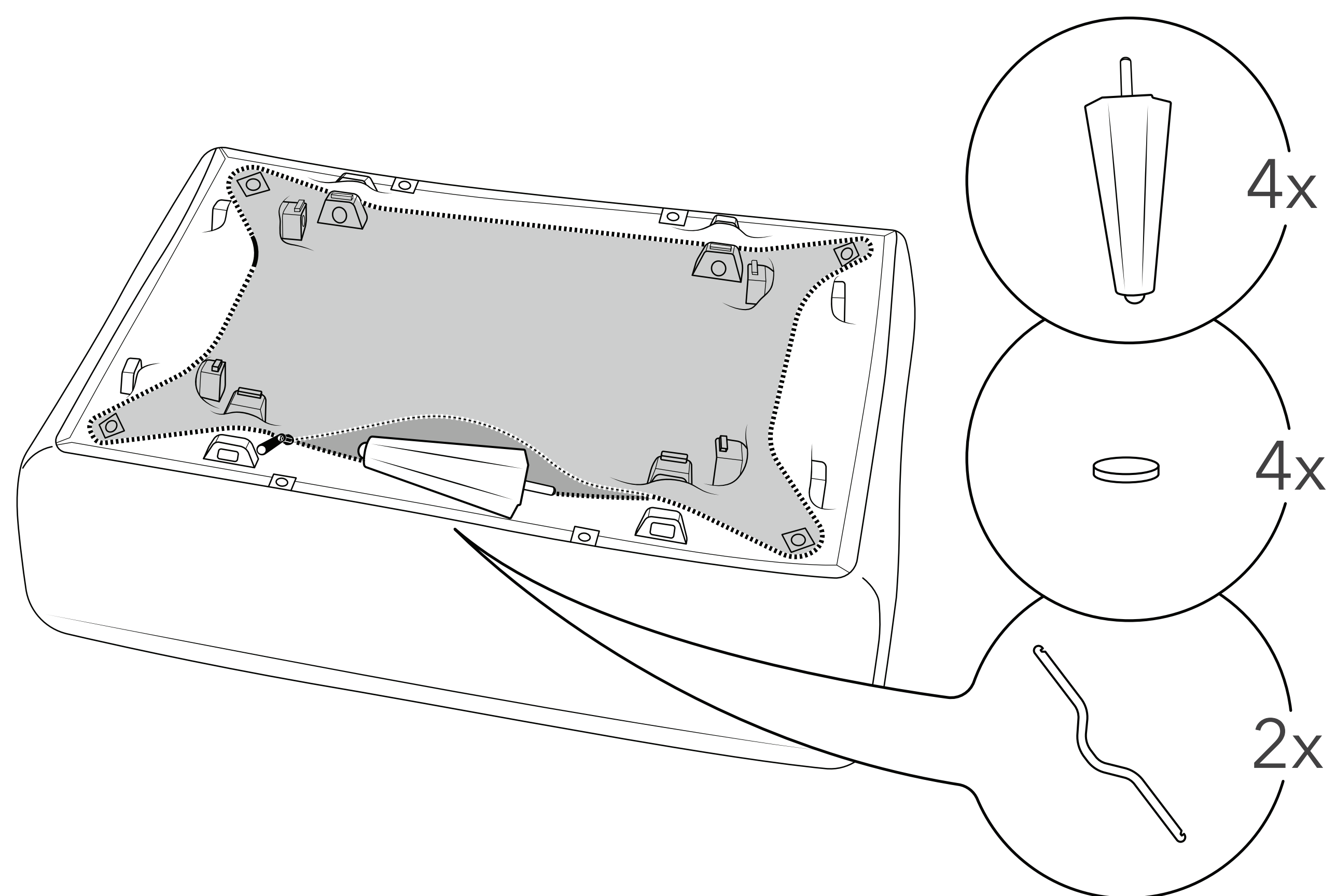

3

### Insert legs into seat A

If you're unable to fully insert the legs with your hands, tap with a mallet.

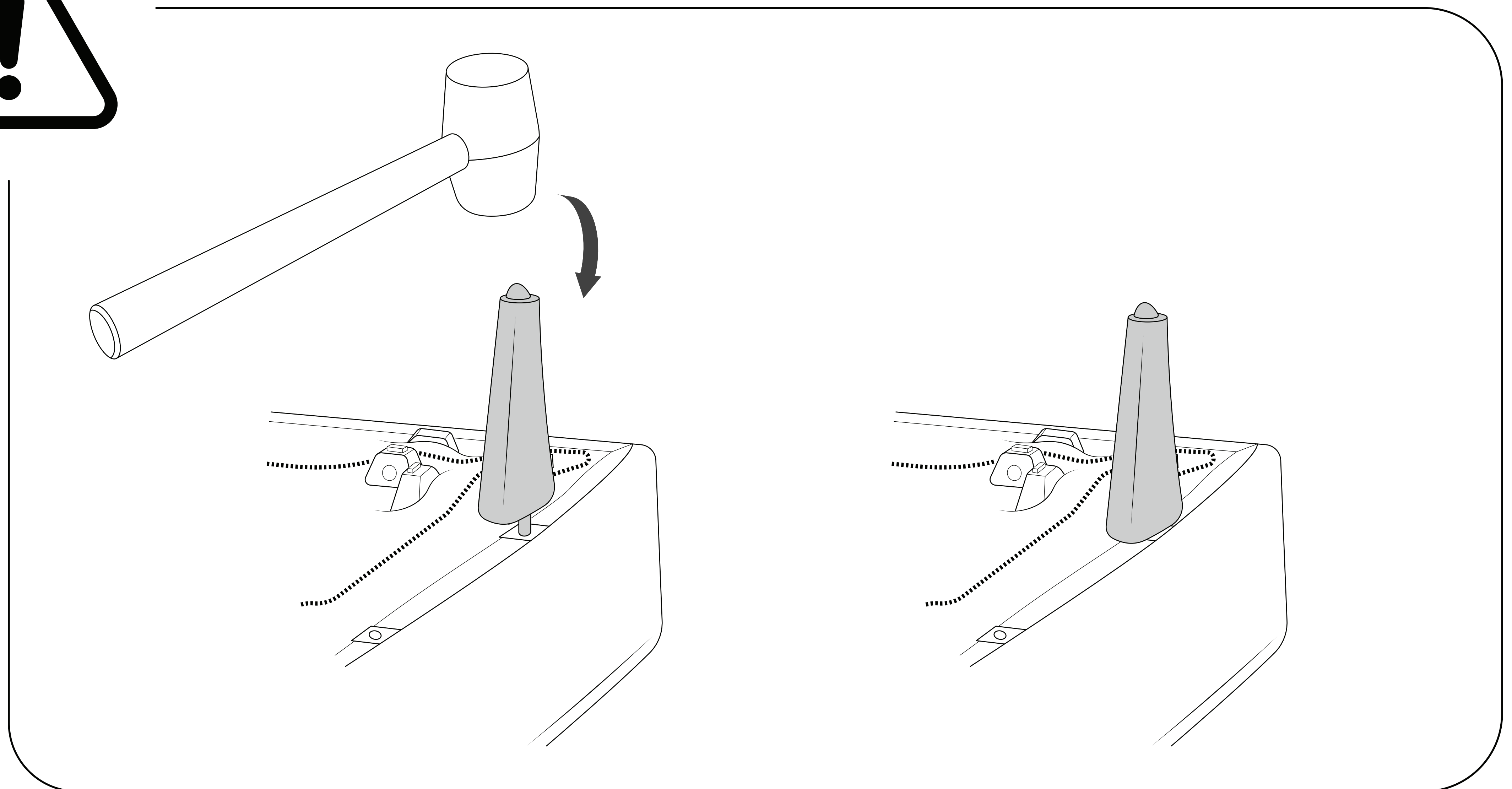
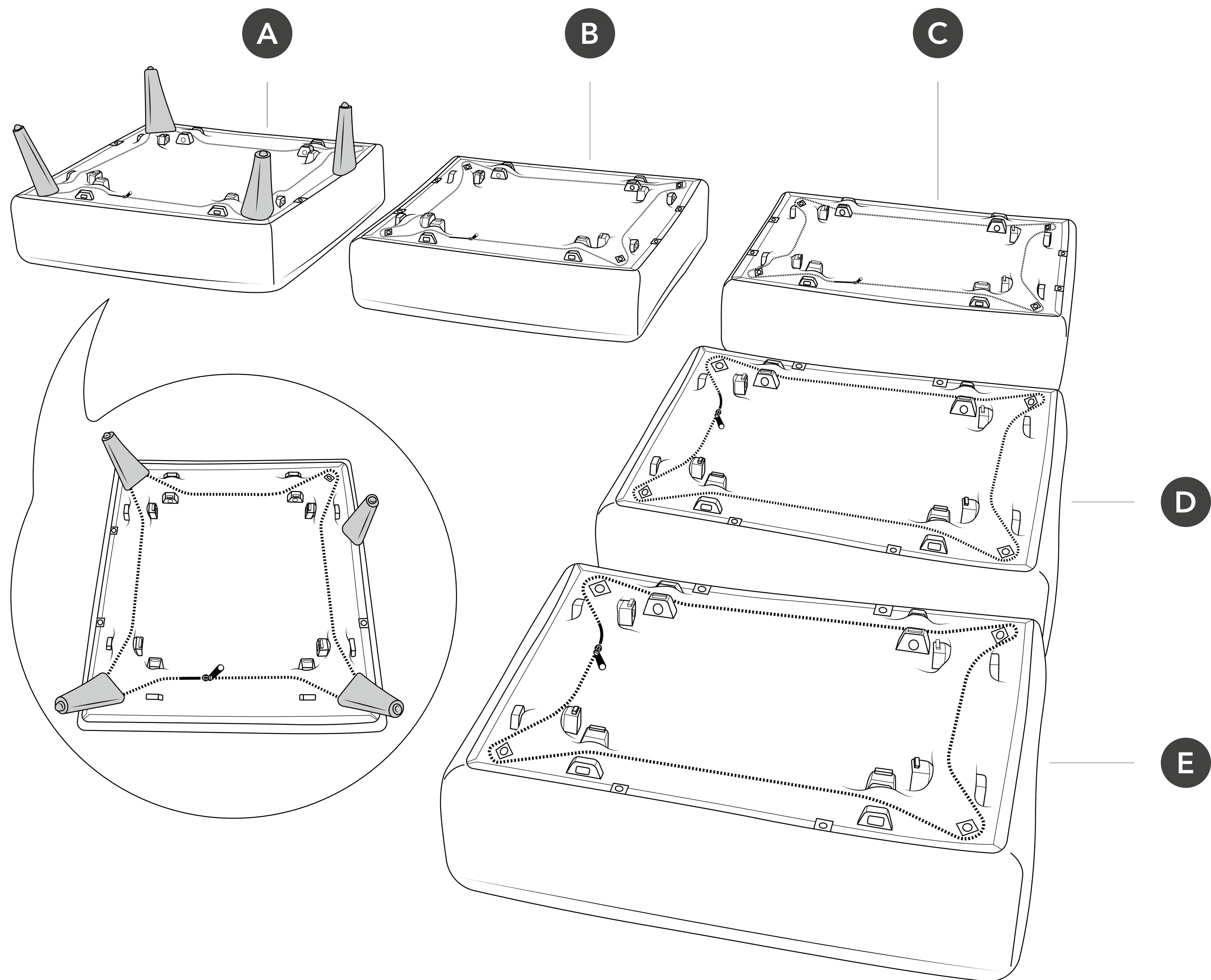

**4** Insert legs into seat B

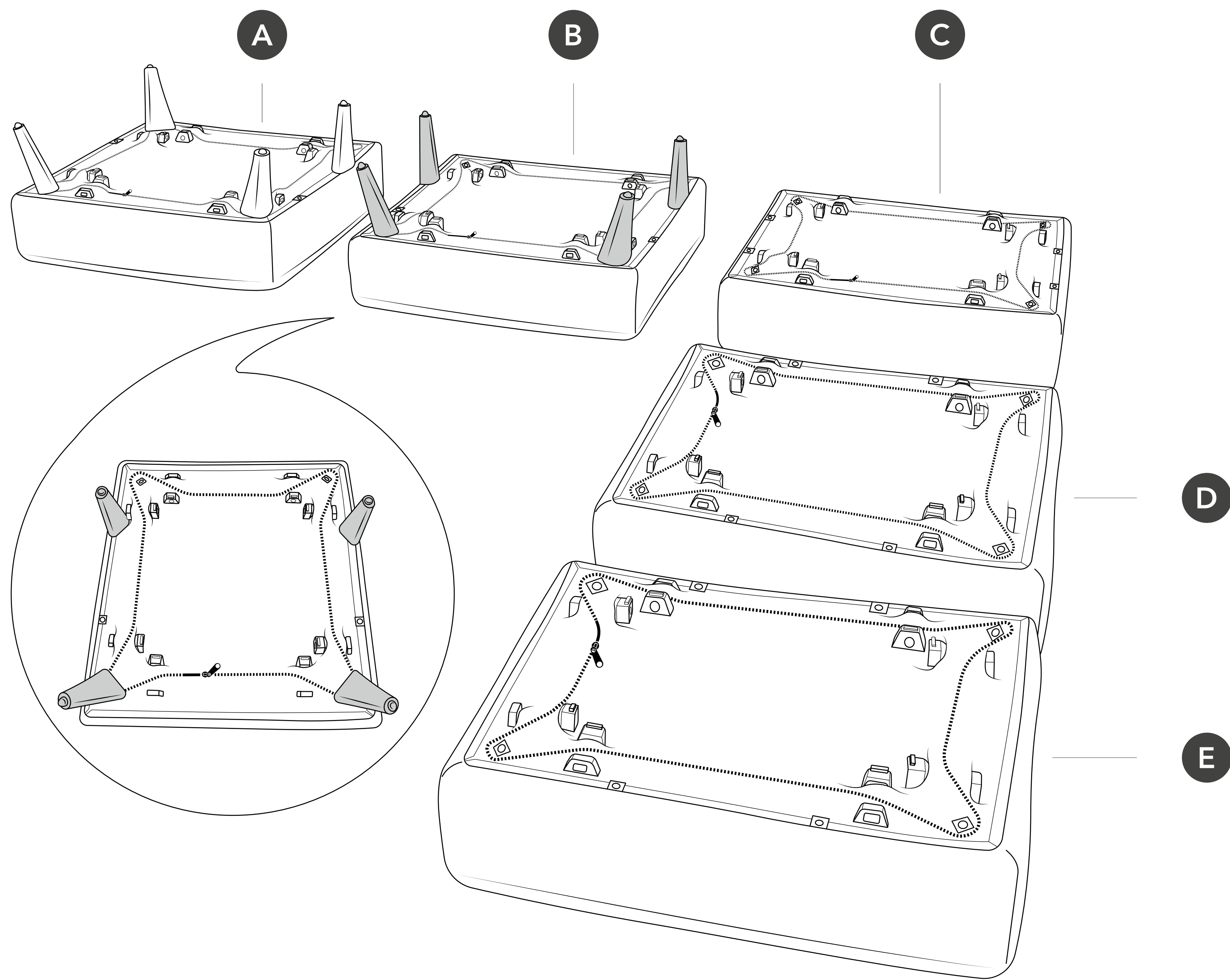

**5** Insert legs into seat C

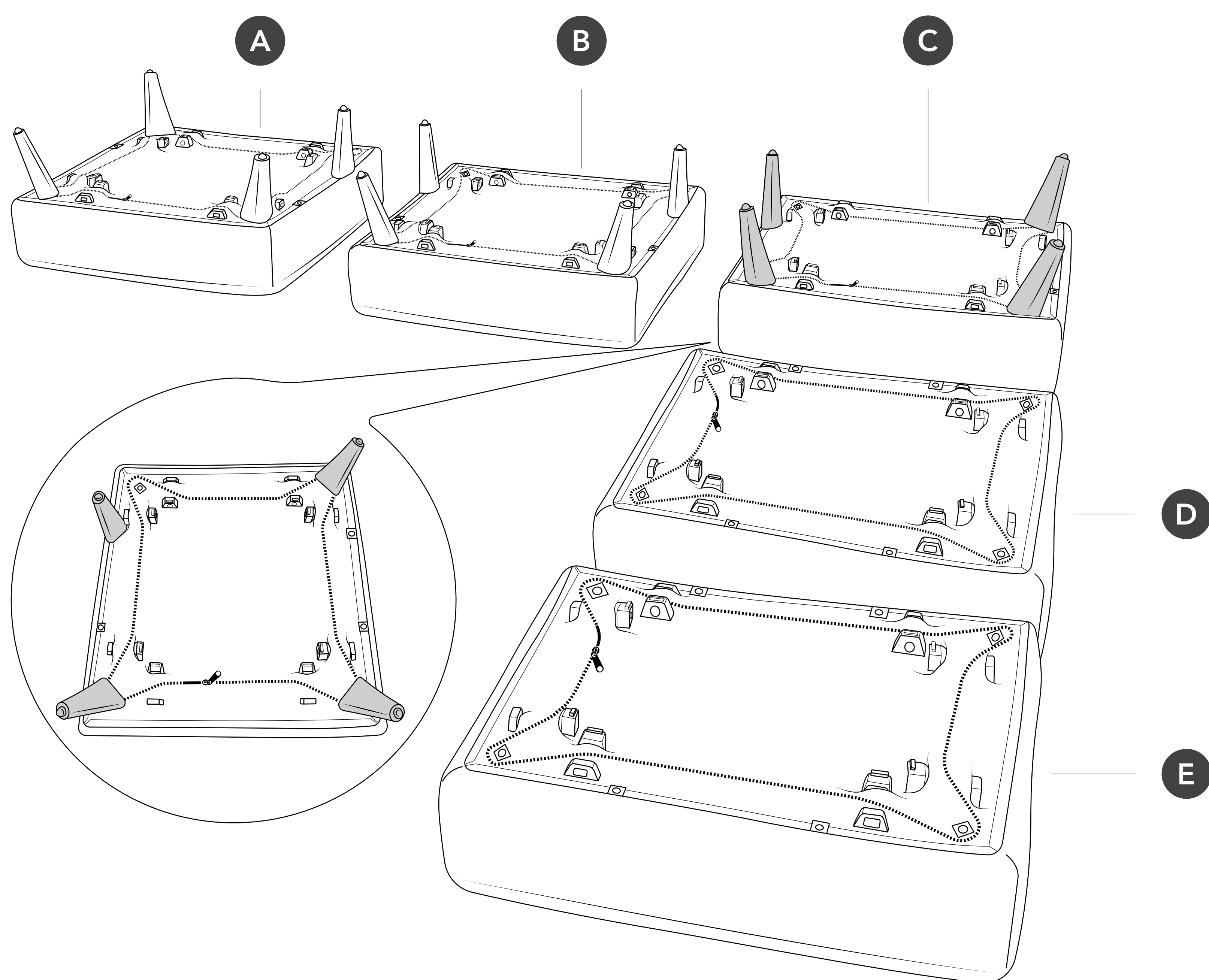

**6** Insert legs into seat D

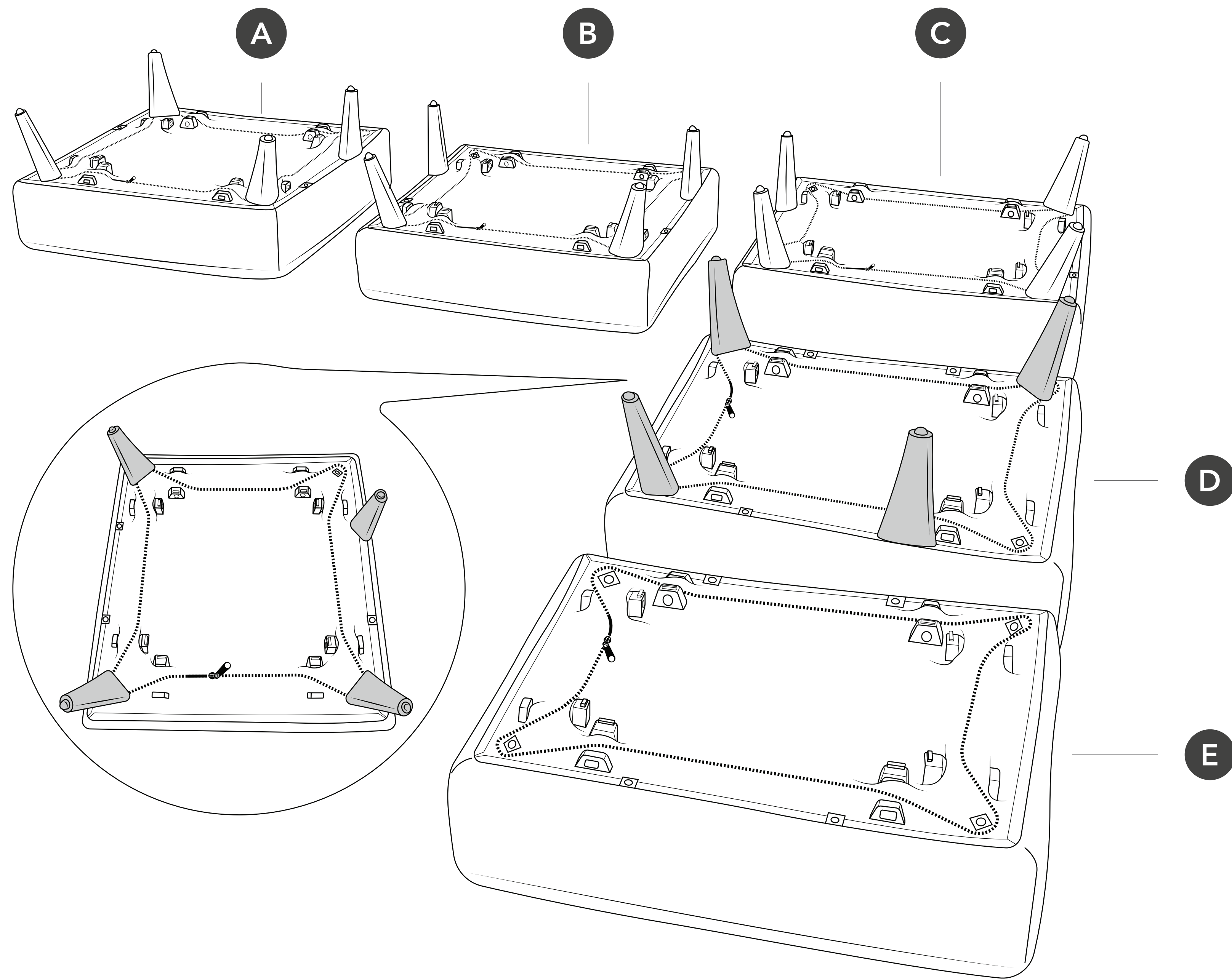

**7** Insert legs into seat E

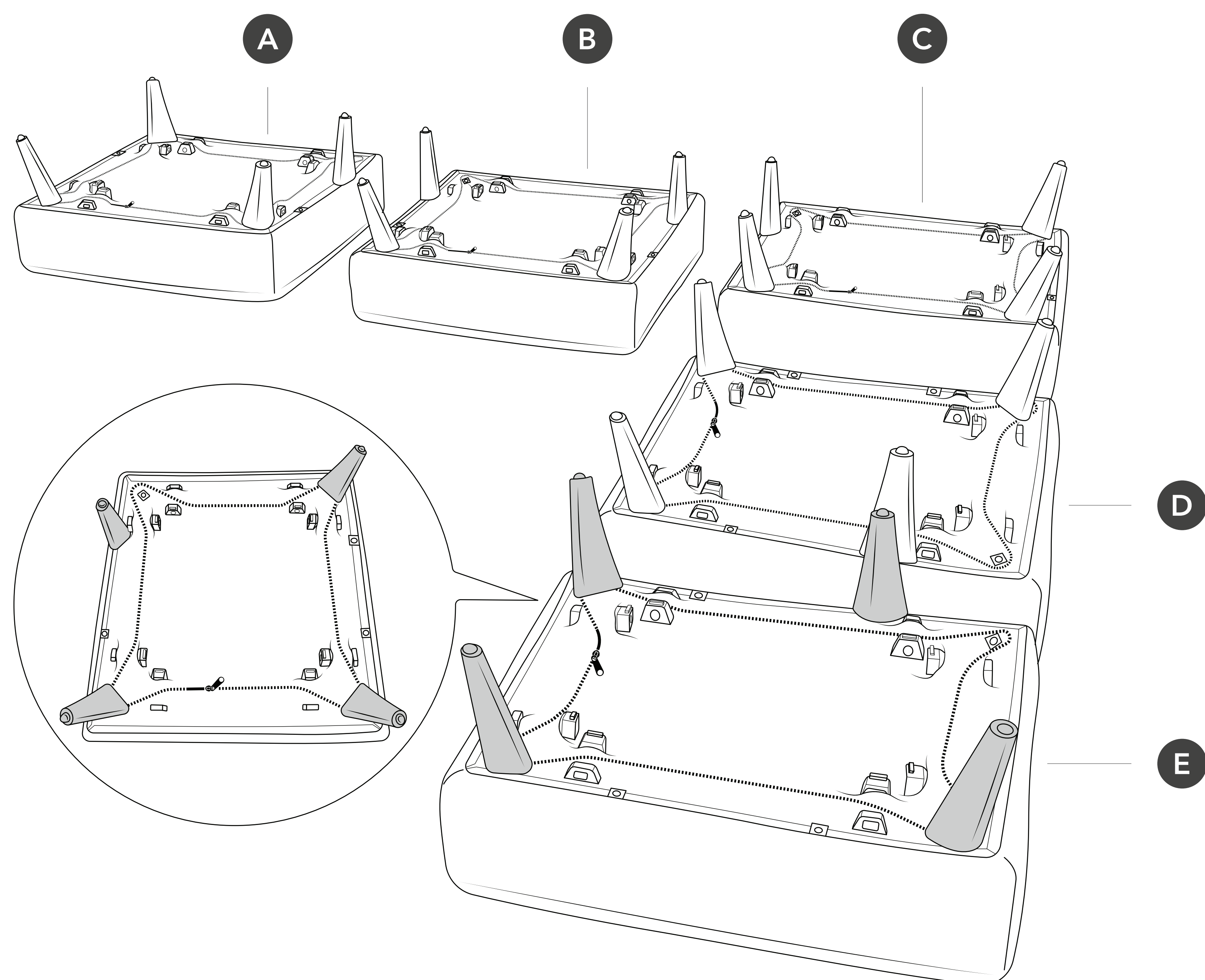

**8** Attach felt pads to the legs

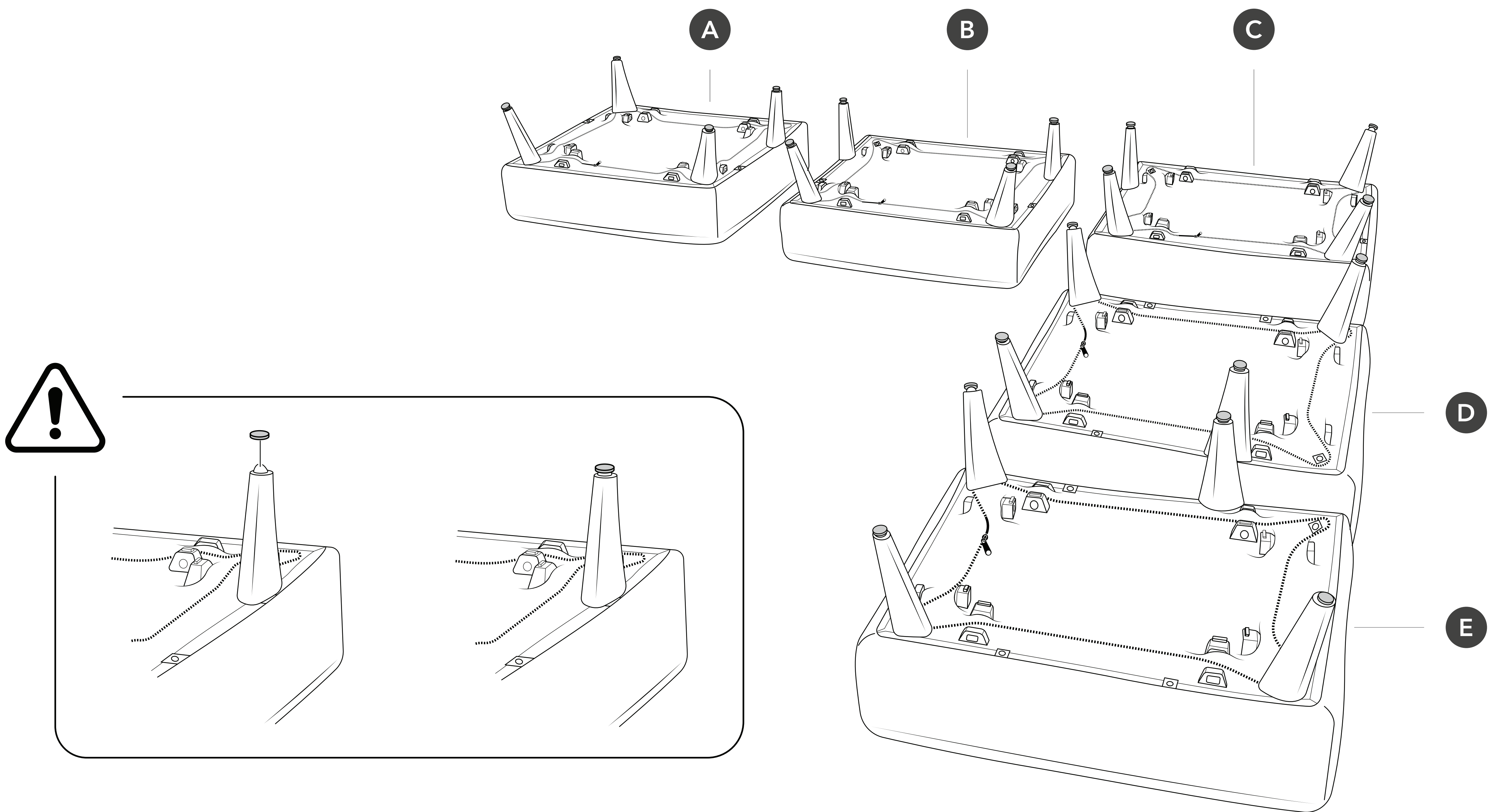

**9** Rotate seat A 90°

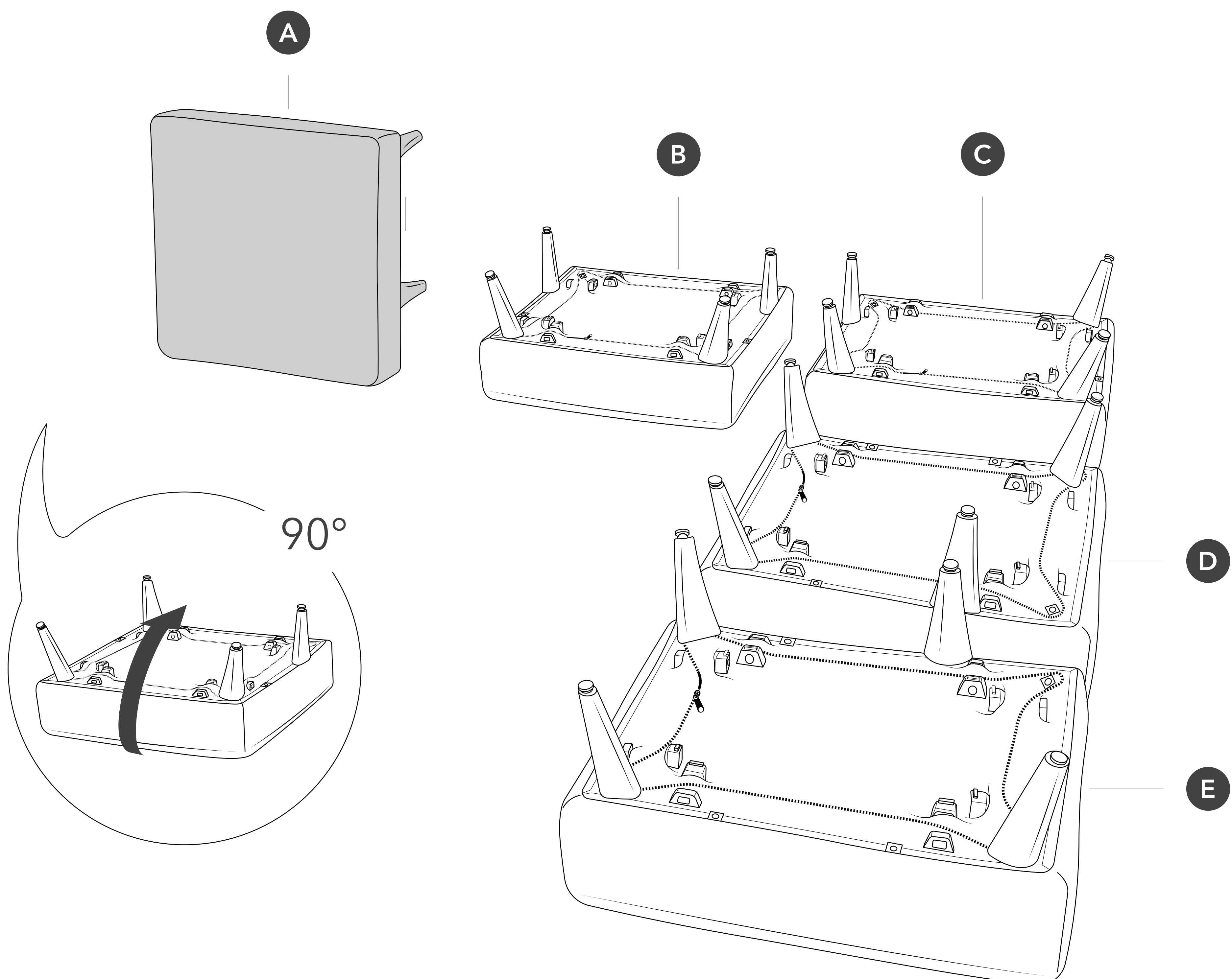

**10** Insert L brackets into cushion  
Insert end with one groove into black hole

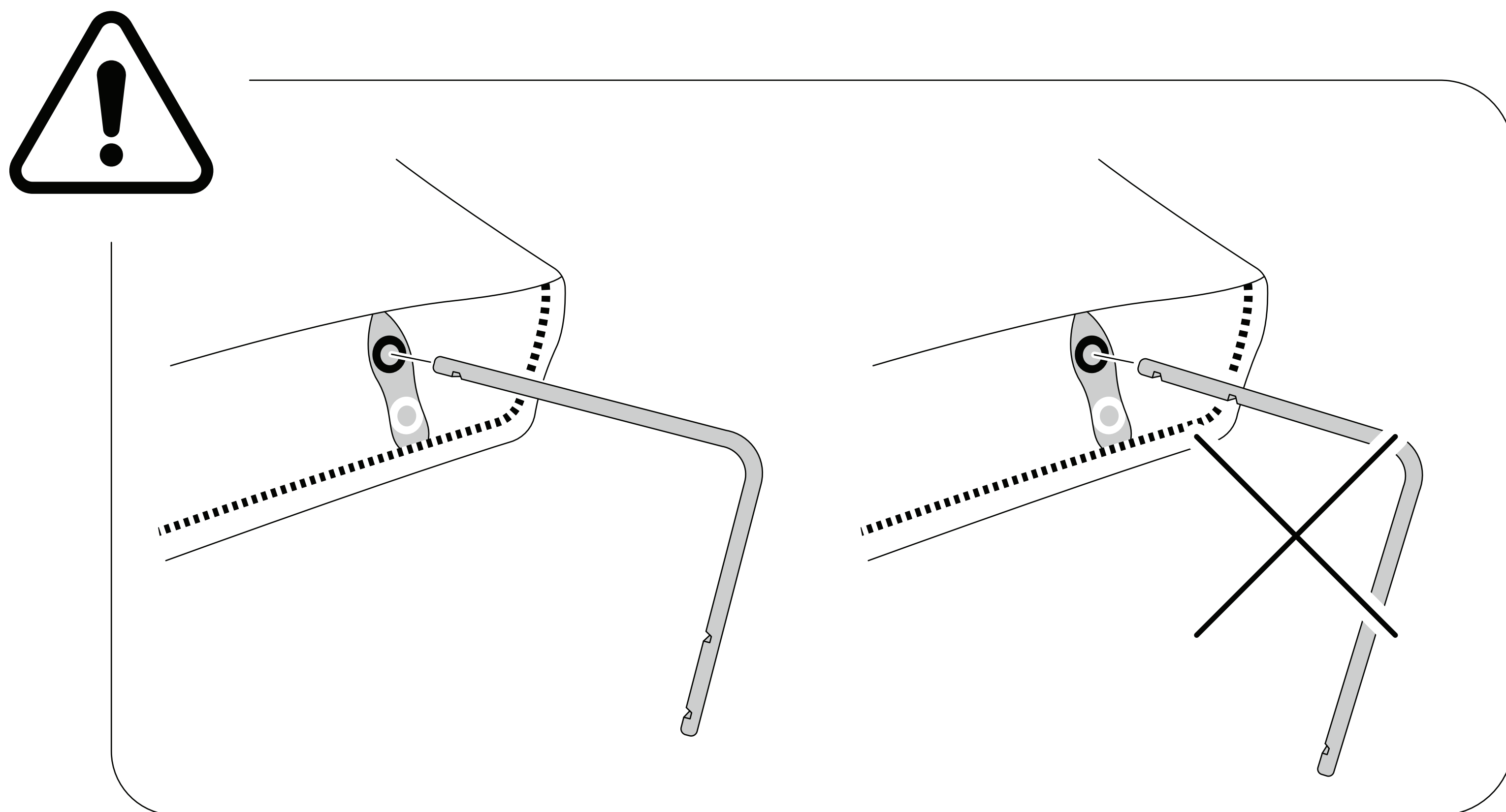
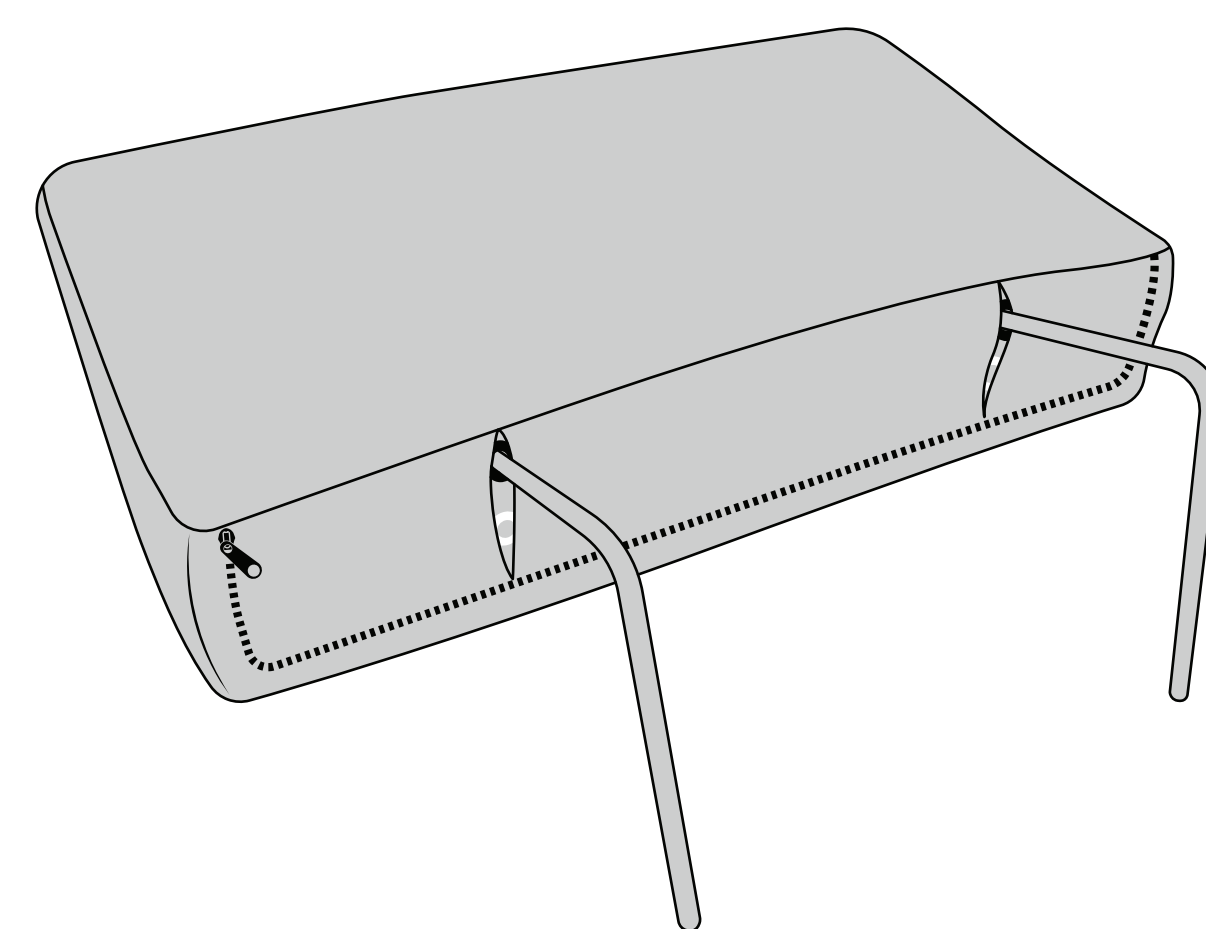
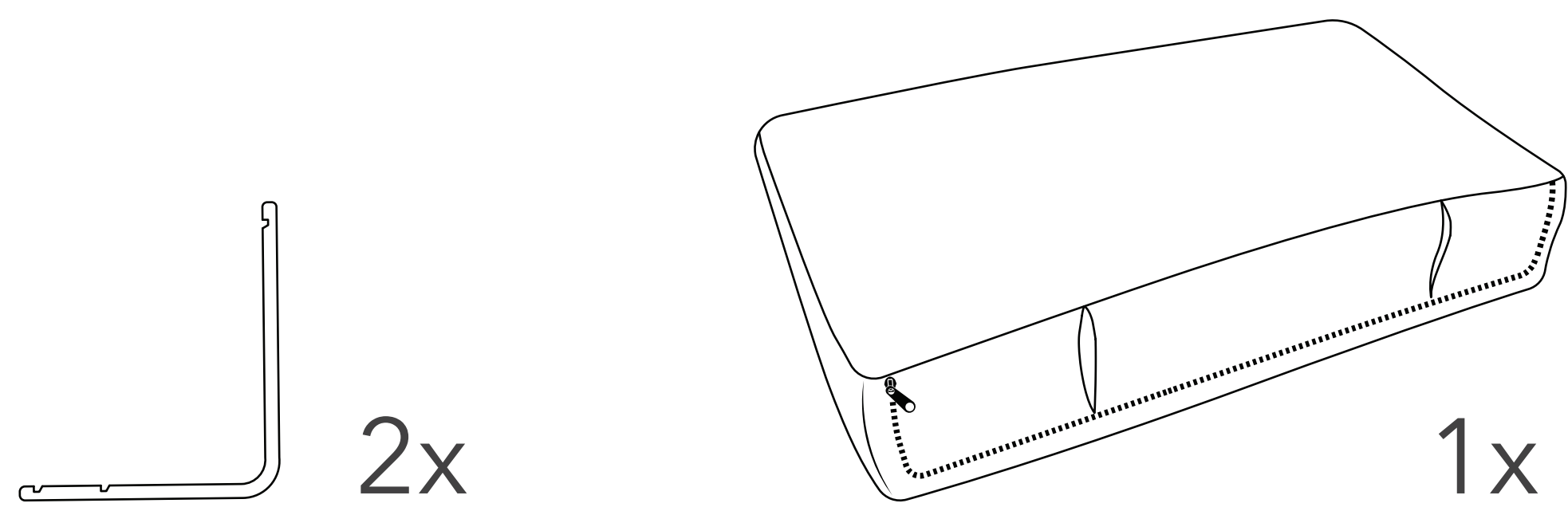

**11** Attach cushion to seat A  
Insert brackets into seat. Listen for the clicks.

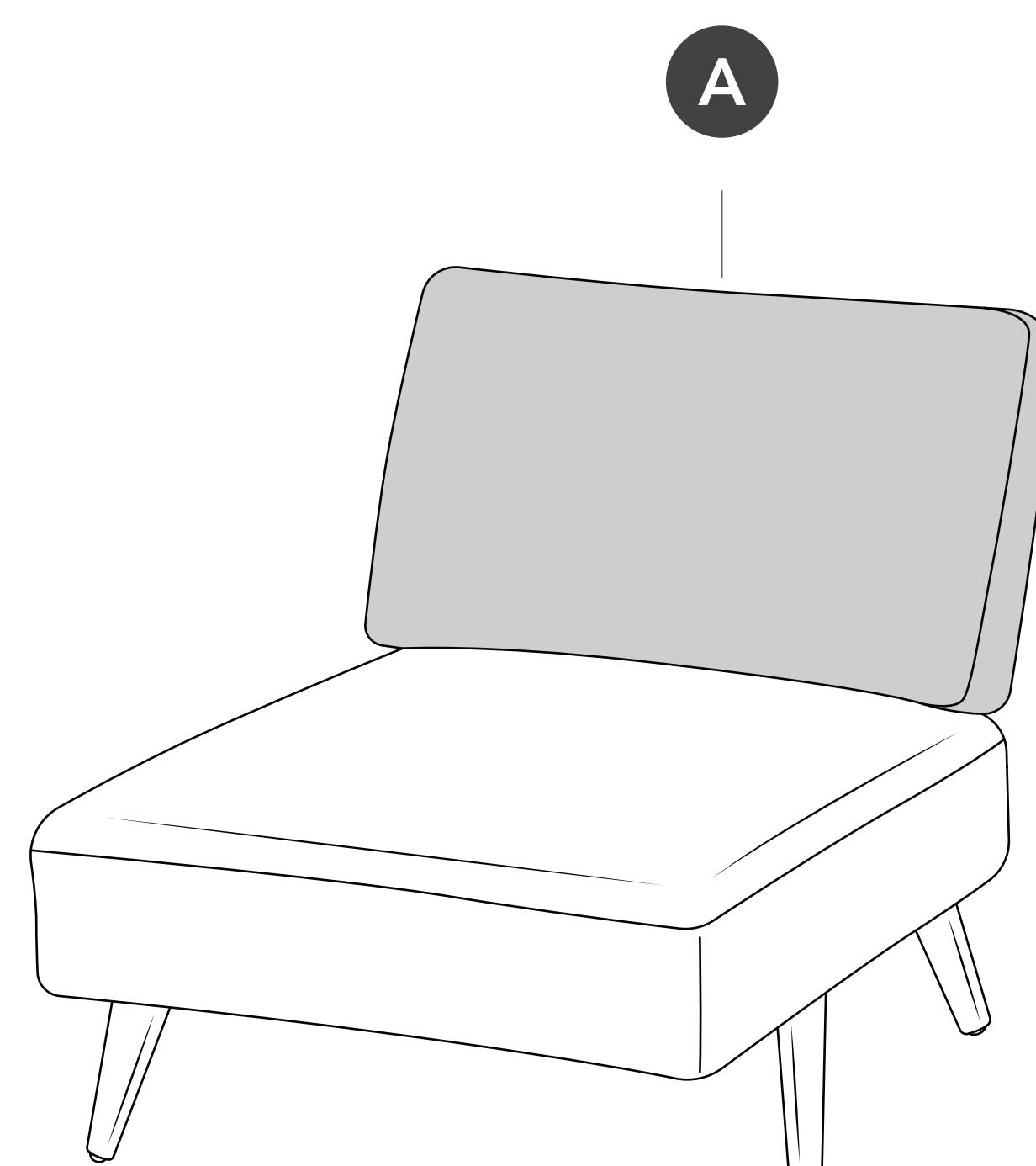
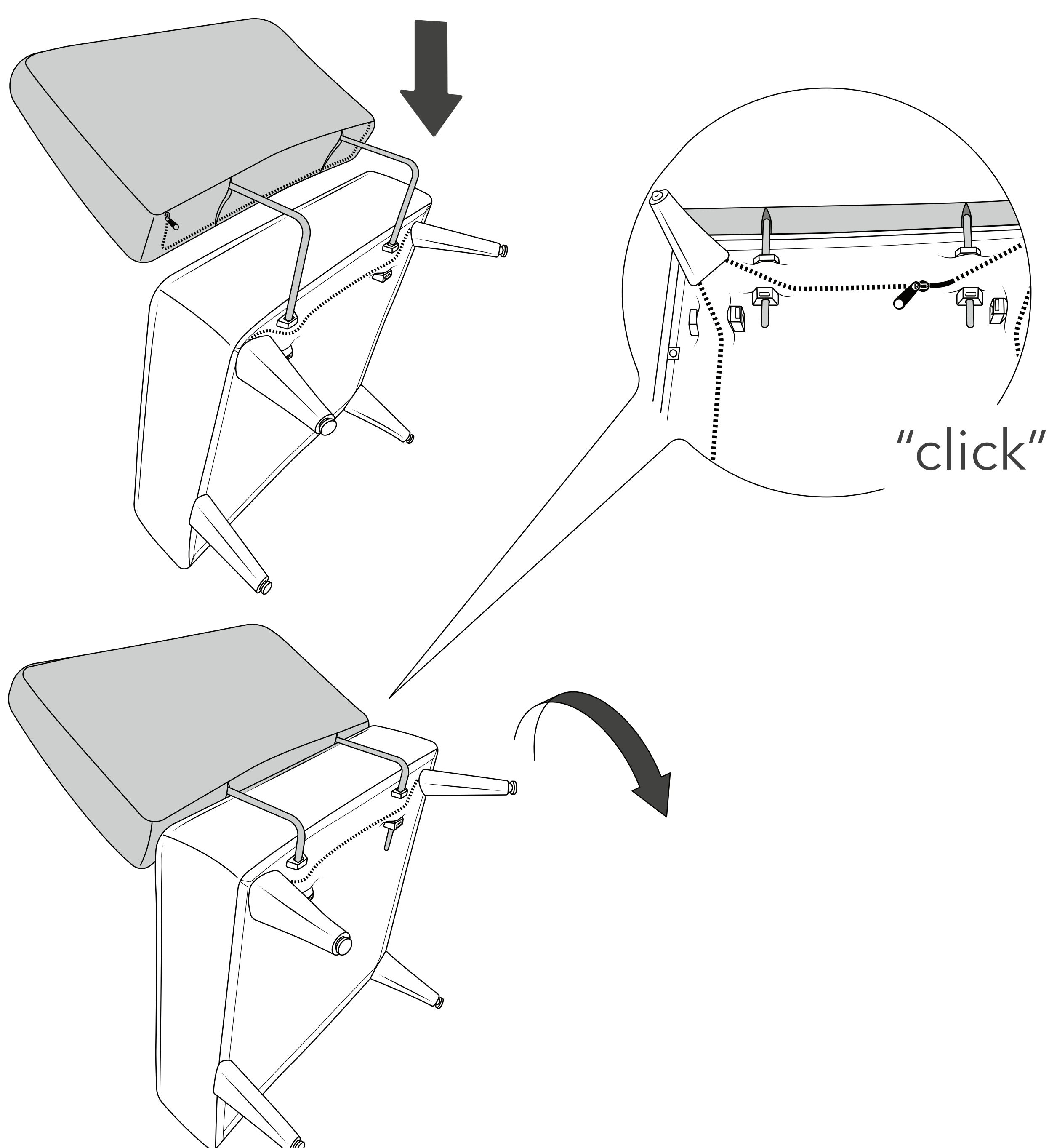

**12** Repeat for cushions B and C

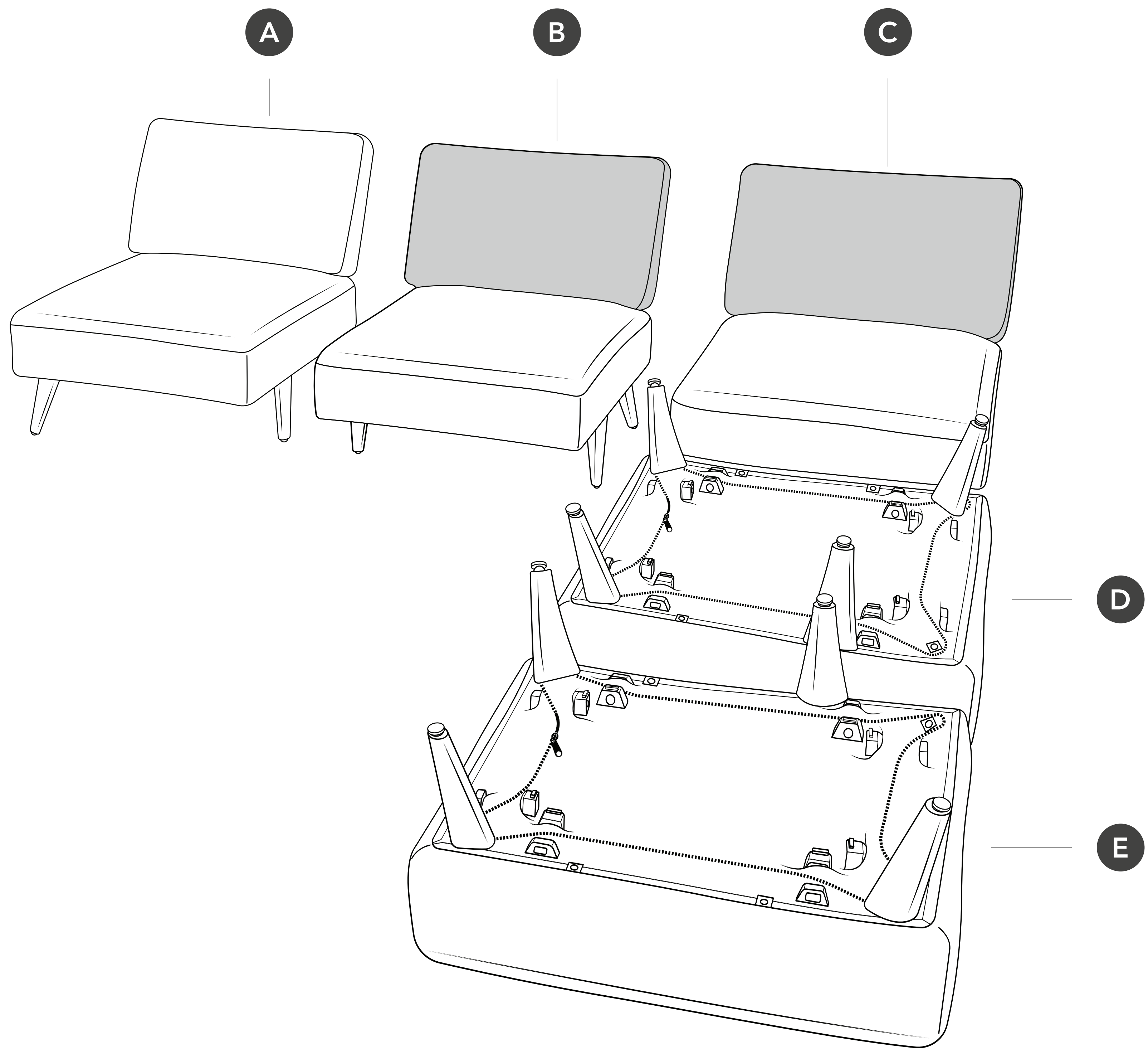

**13** Rotate seats D and E 180°

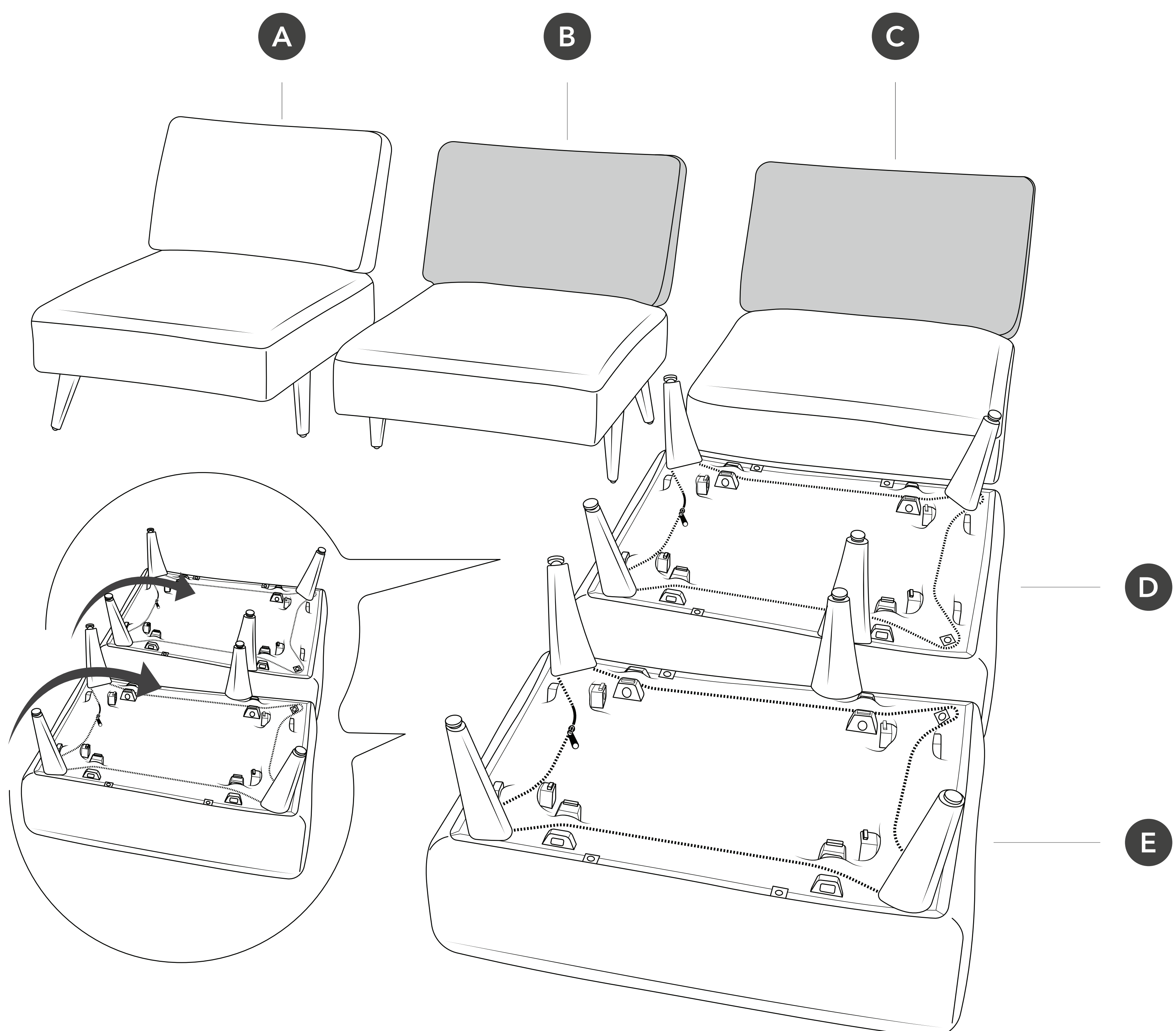



14

**Join seats B and C**

Insert joiner brackets into seat B and then slide seat C onto joiner brackets. Listen for the clicks.

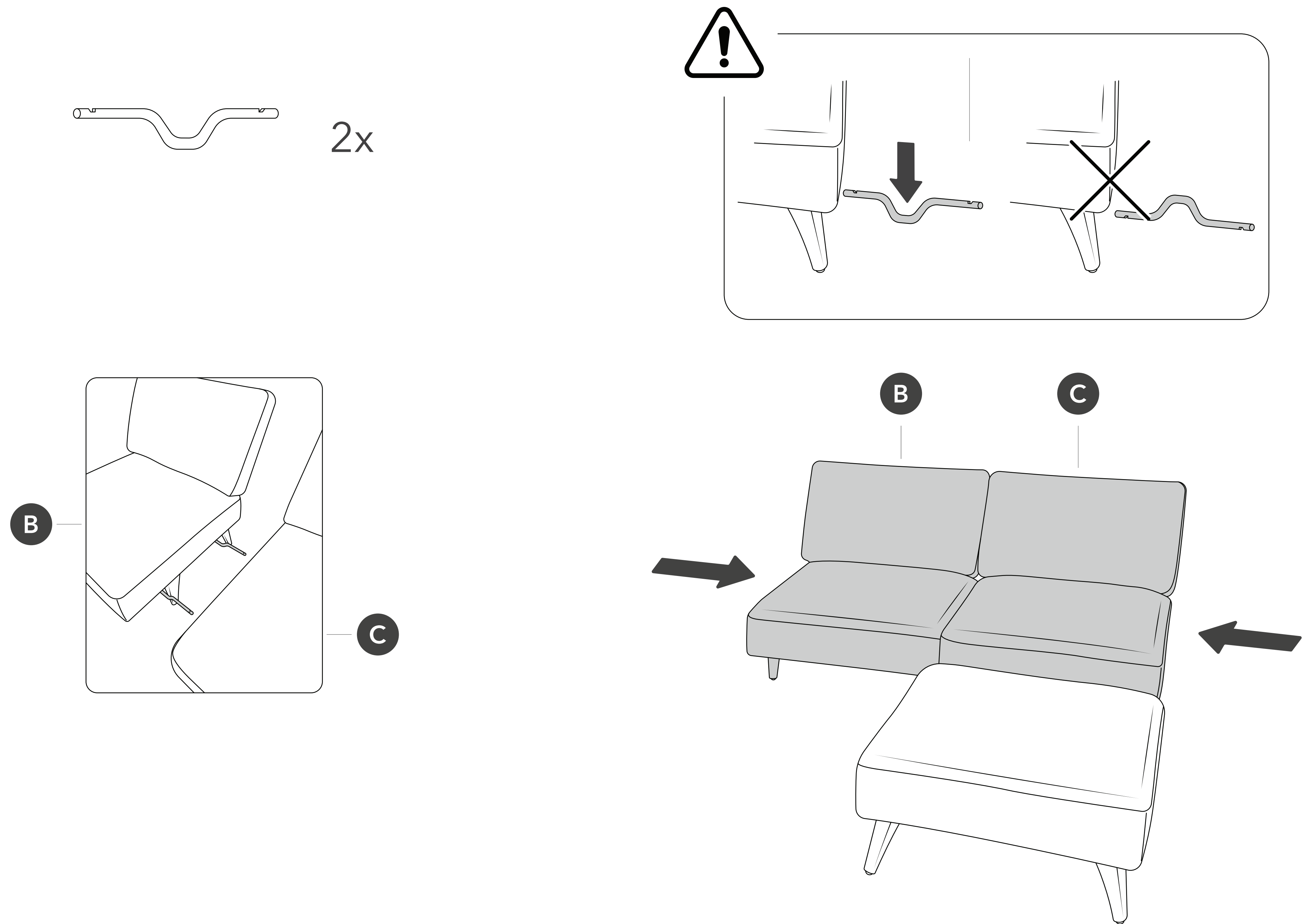

15

**Join seats A and B**

Listen for the clicks.

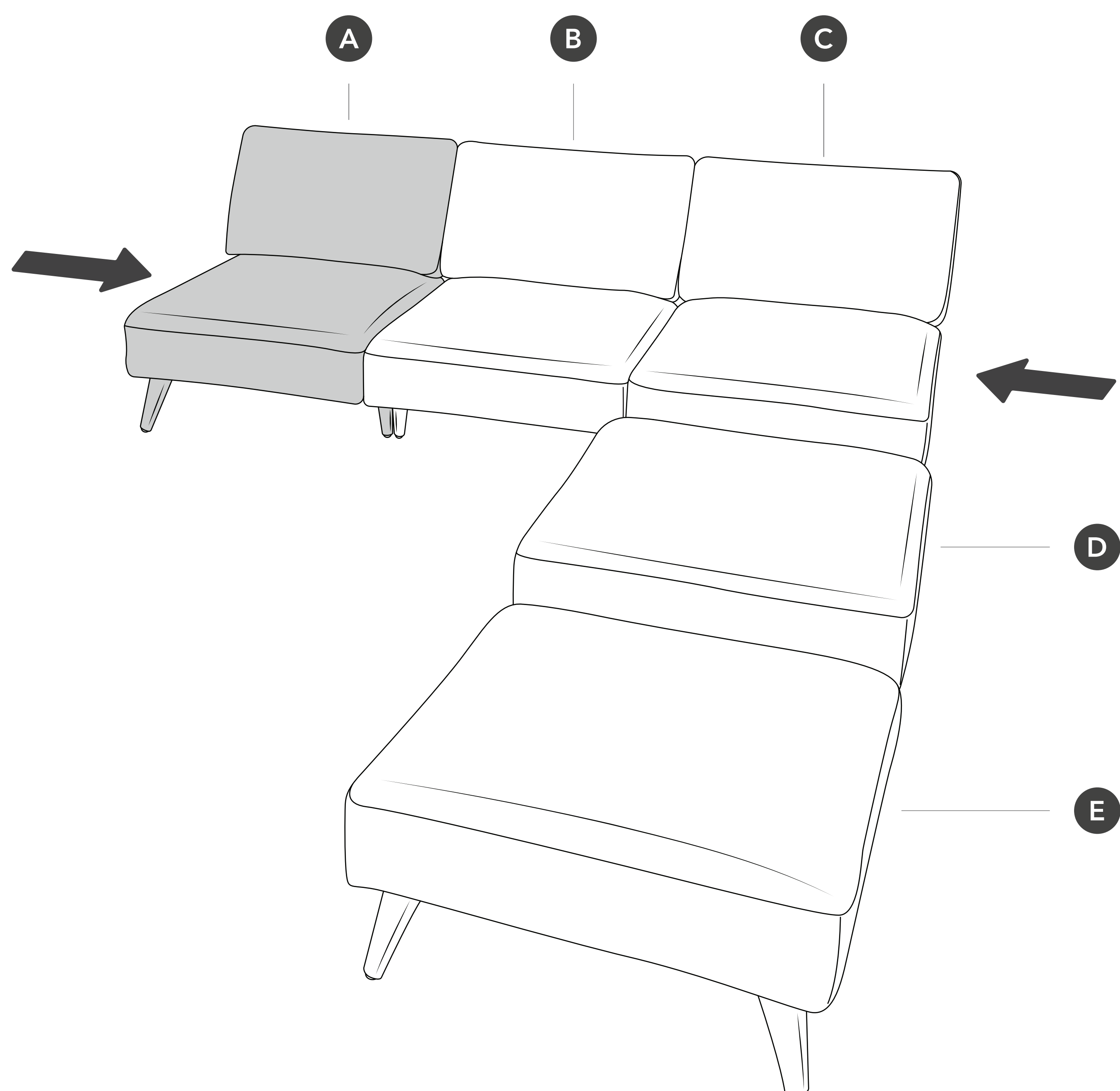

**16** Join seats C and D  
Listen for the clicks.

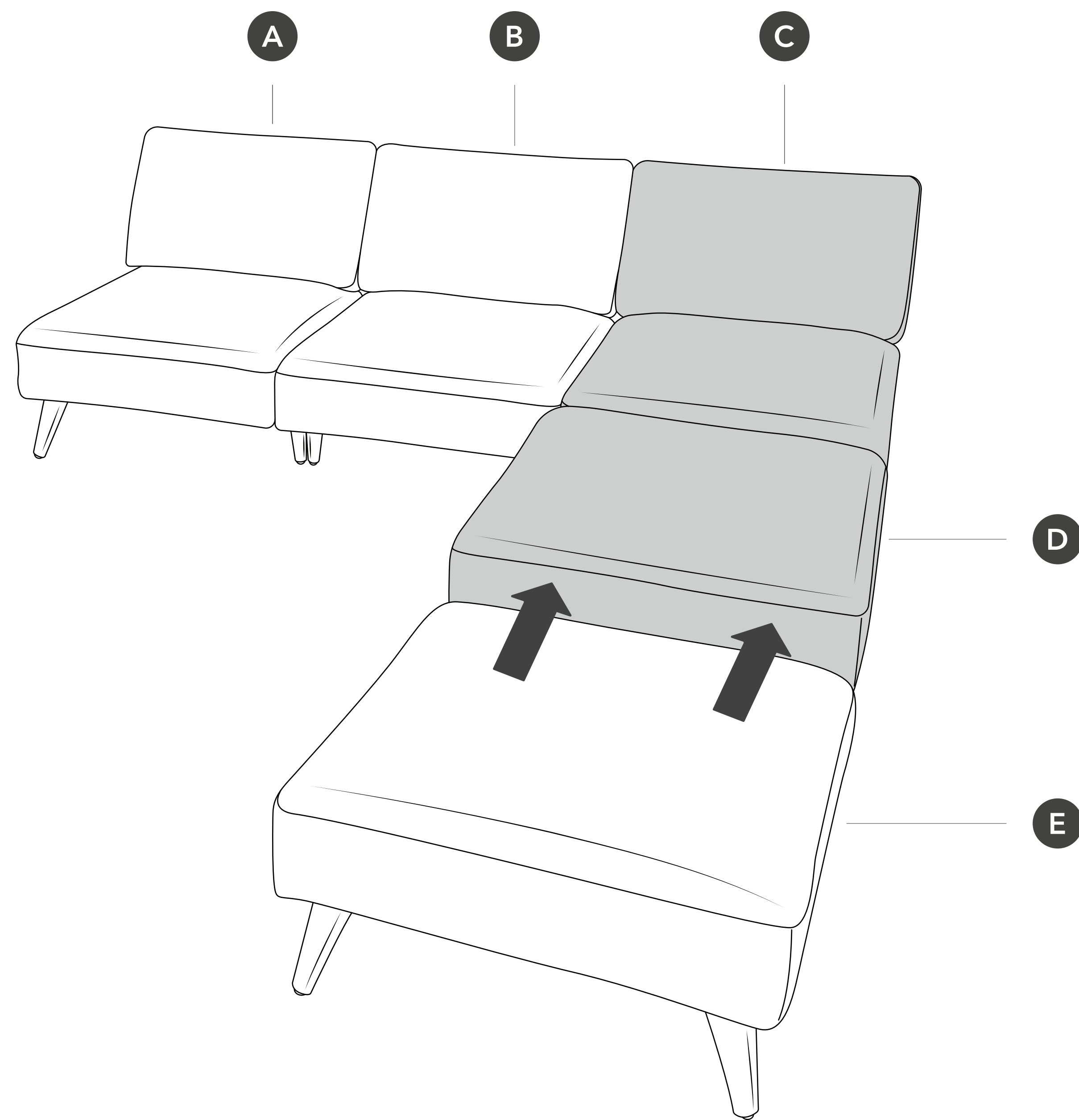

**17** Join seats D and E  
Listen for the clicks.

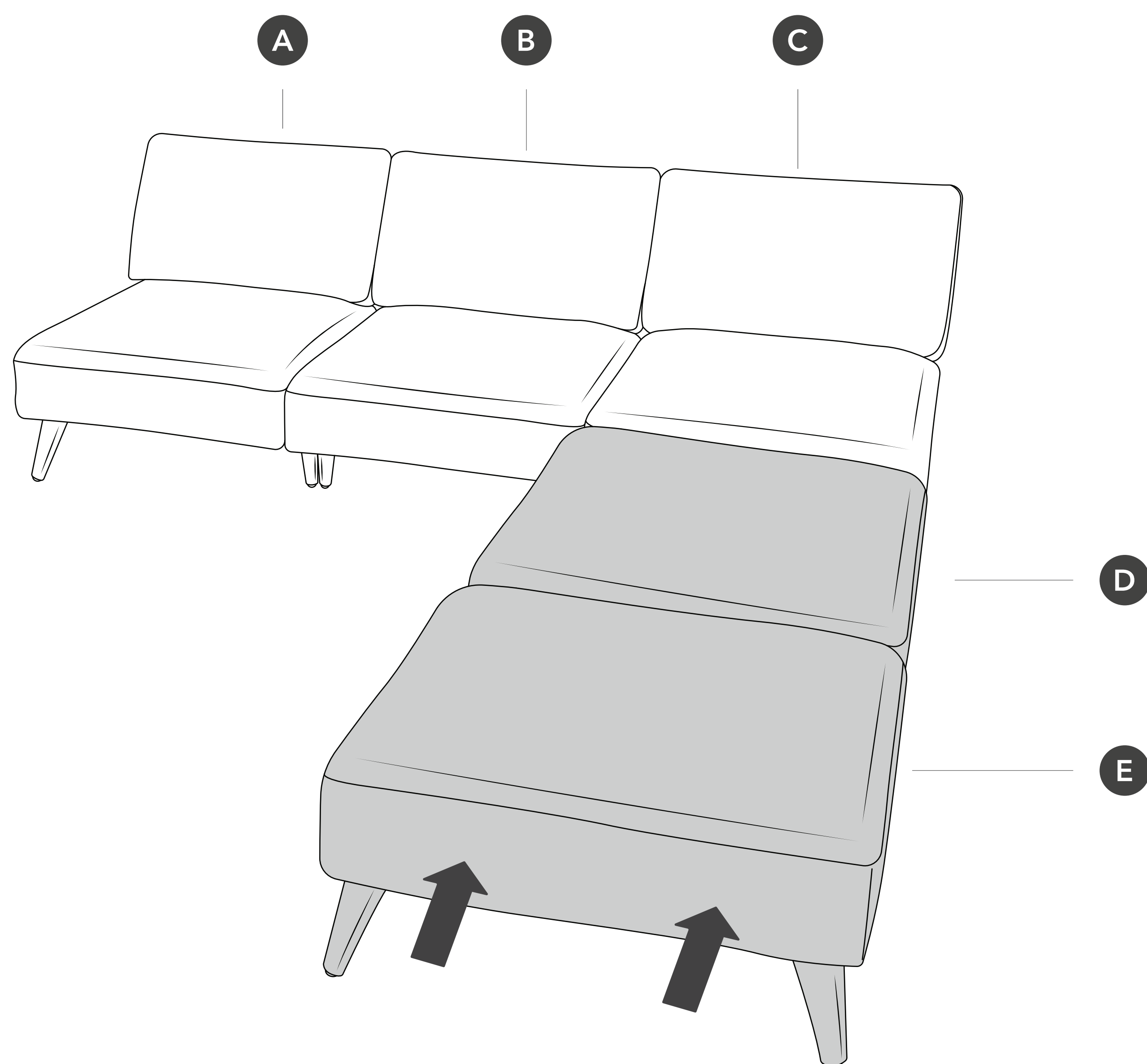

18

### Insert L brackets into cushion

Insert end with one groove into black hole

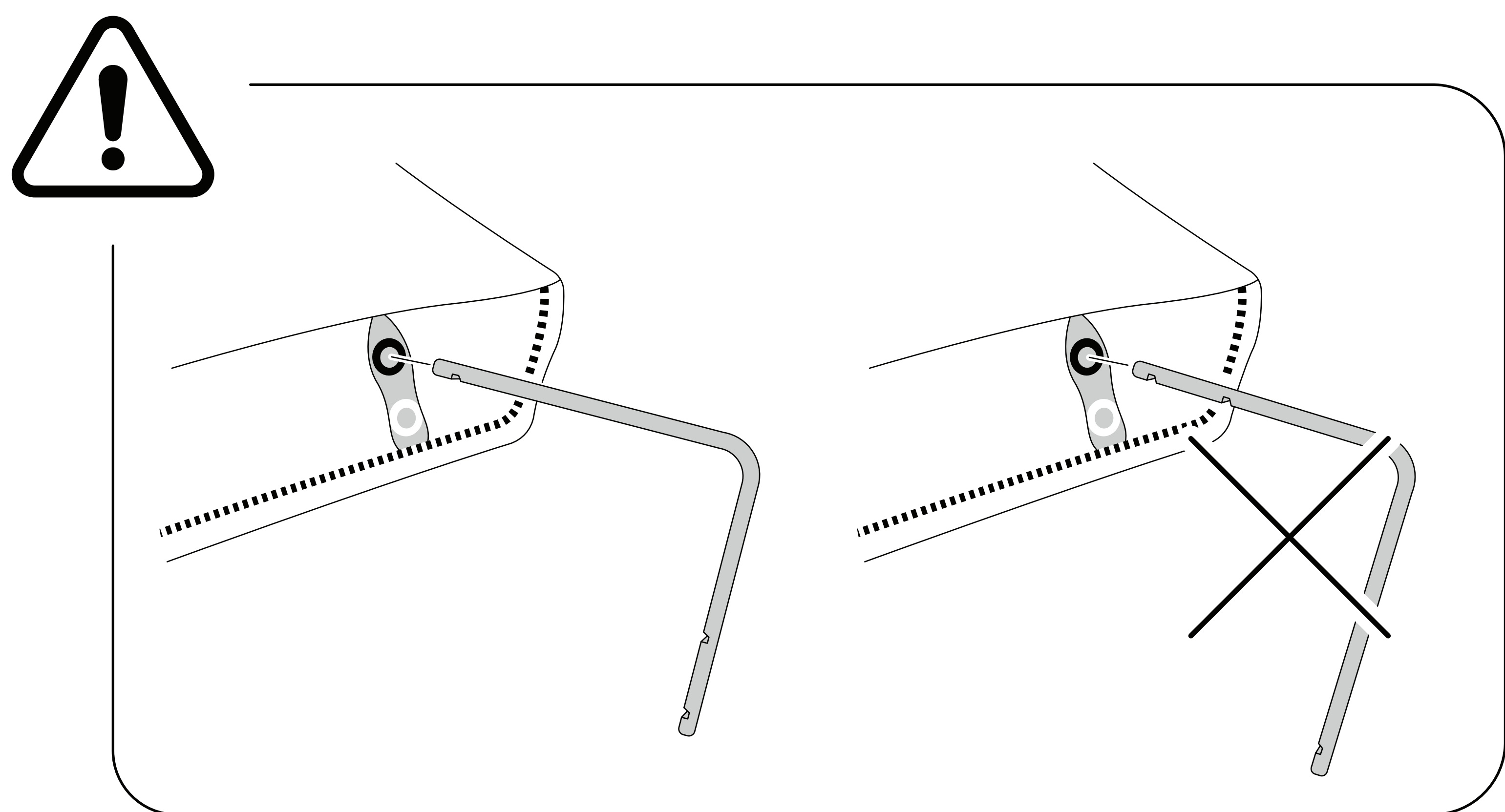
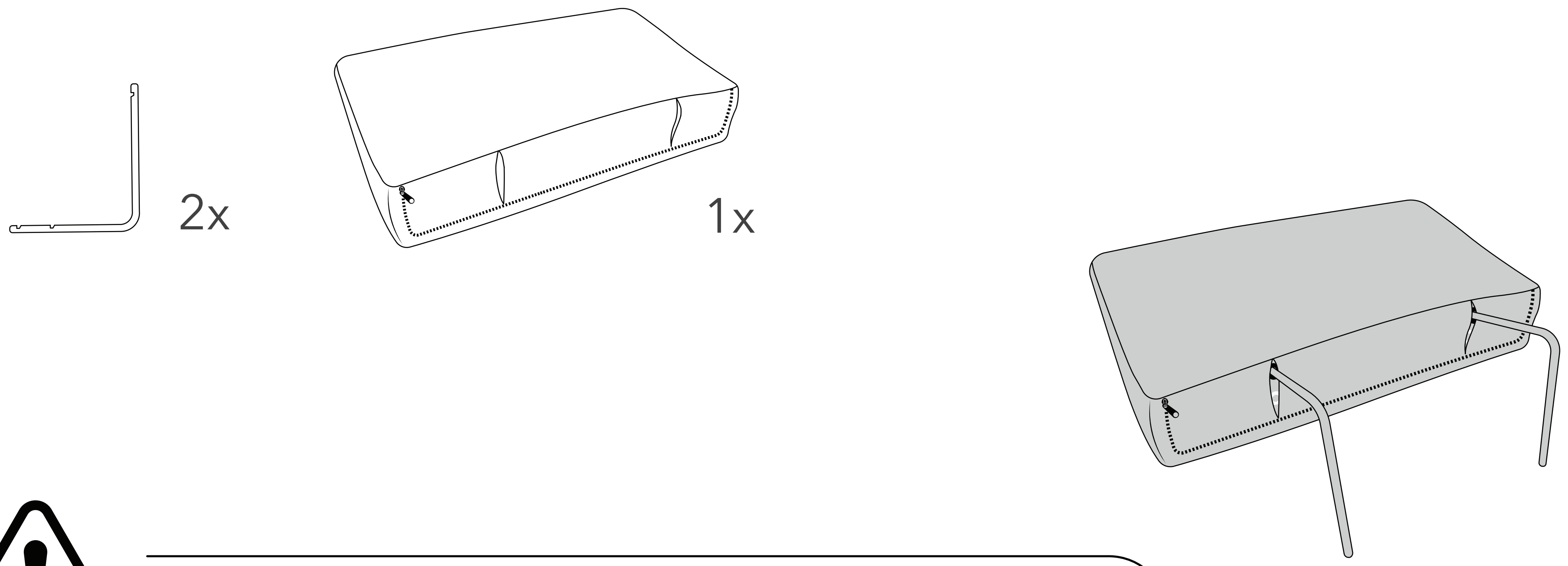

19

### Attach cushion to seat C

Insert brackets into seat C. Listen for the clicks.

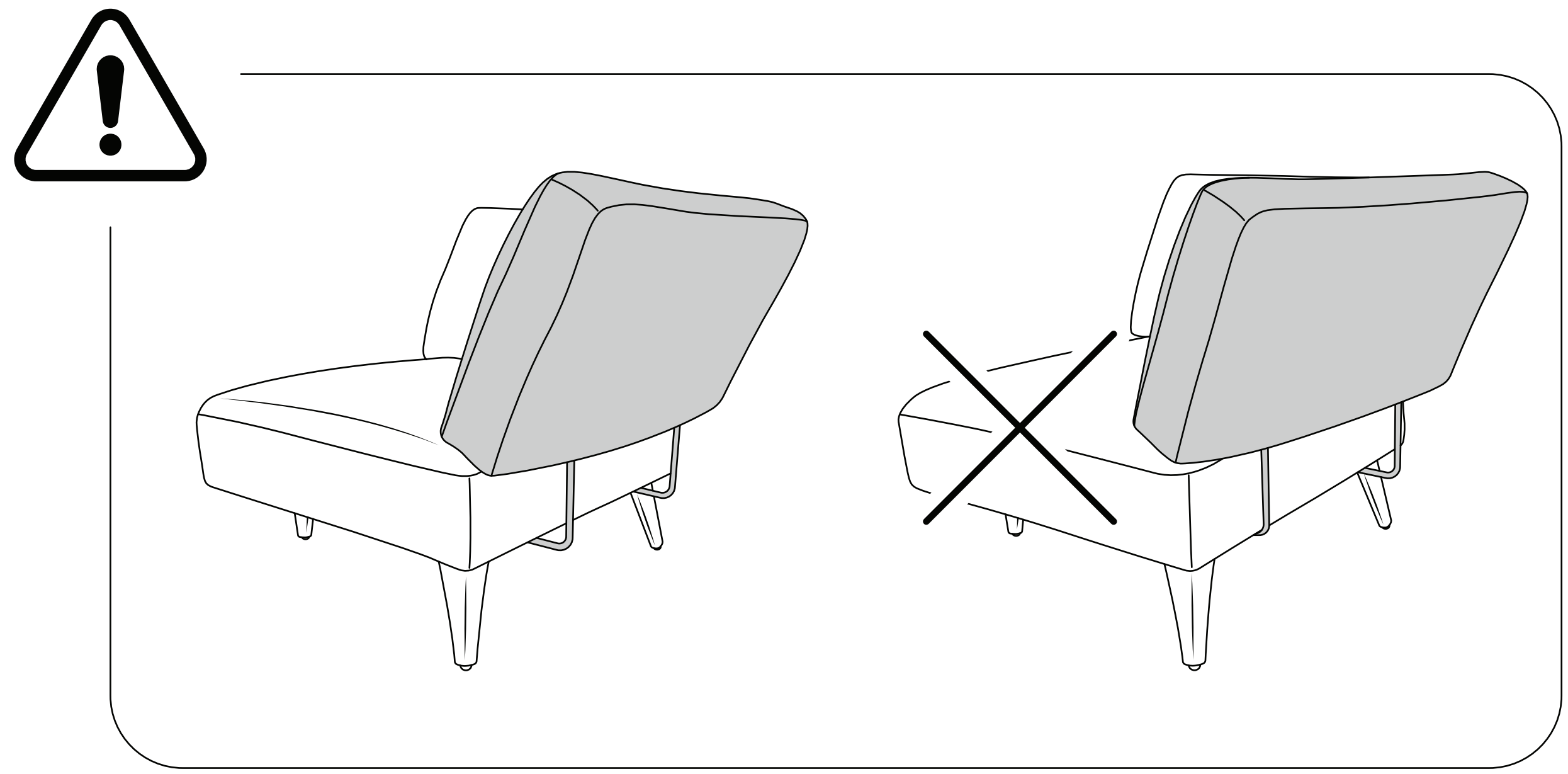
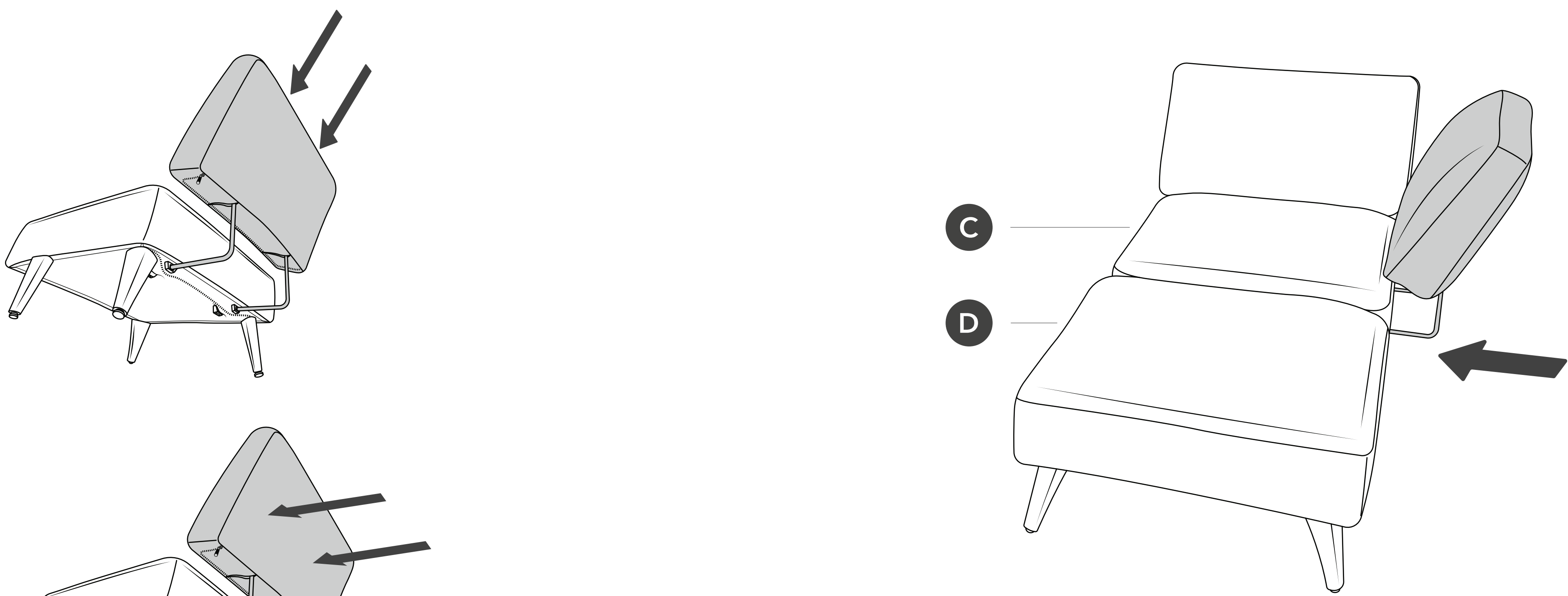

**20** Attach cushion to seat D and E  
Listen for the clicks.

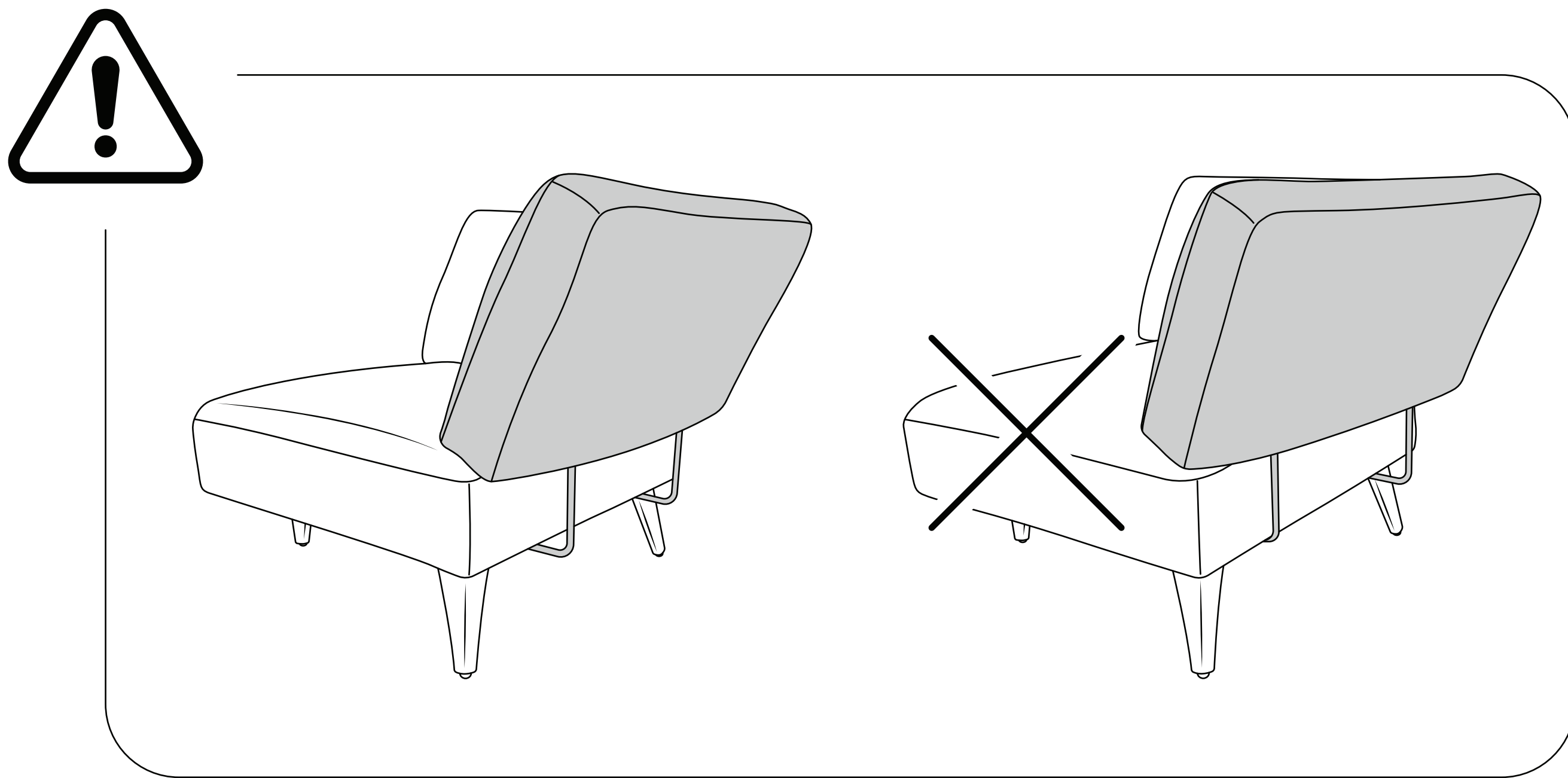
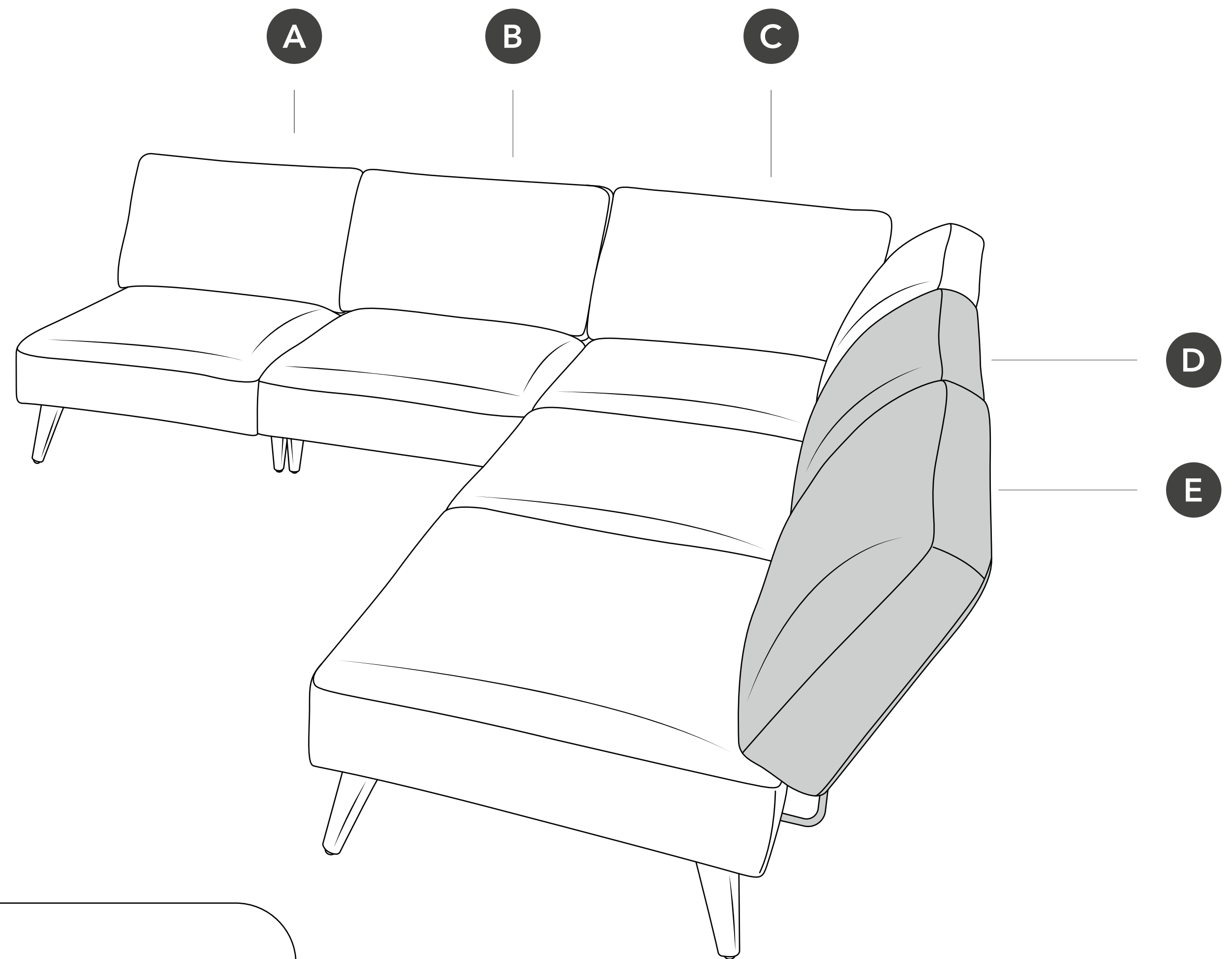

**21** Adjust cushion for use as an arm  
Unzip cover and swing black brackets 90°. Zip cover closed.

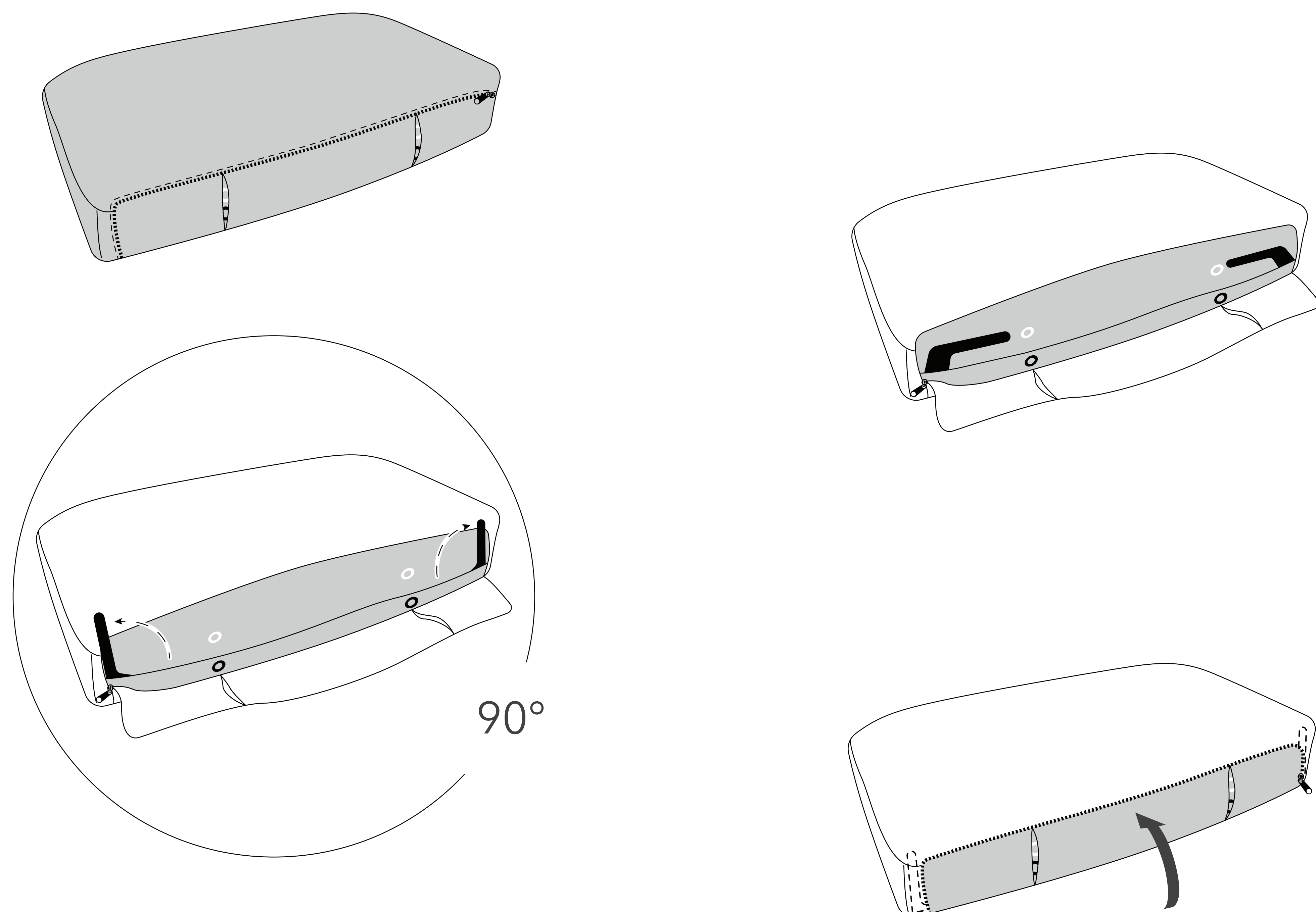

22

### Insert L brackets into cushion

Insert end with two grooves into white hole

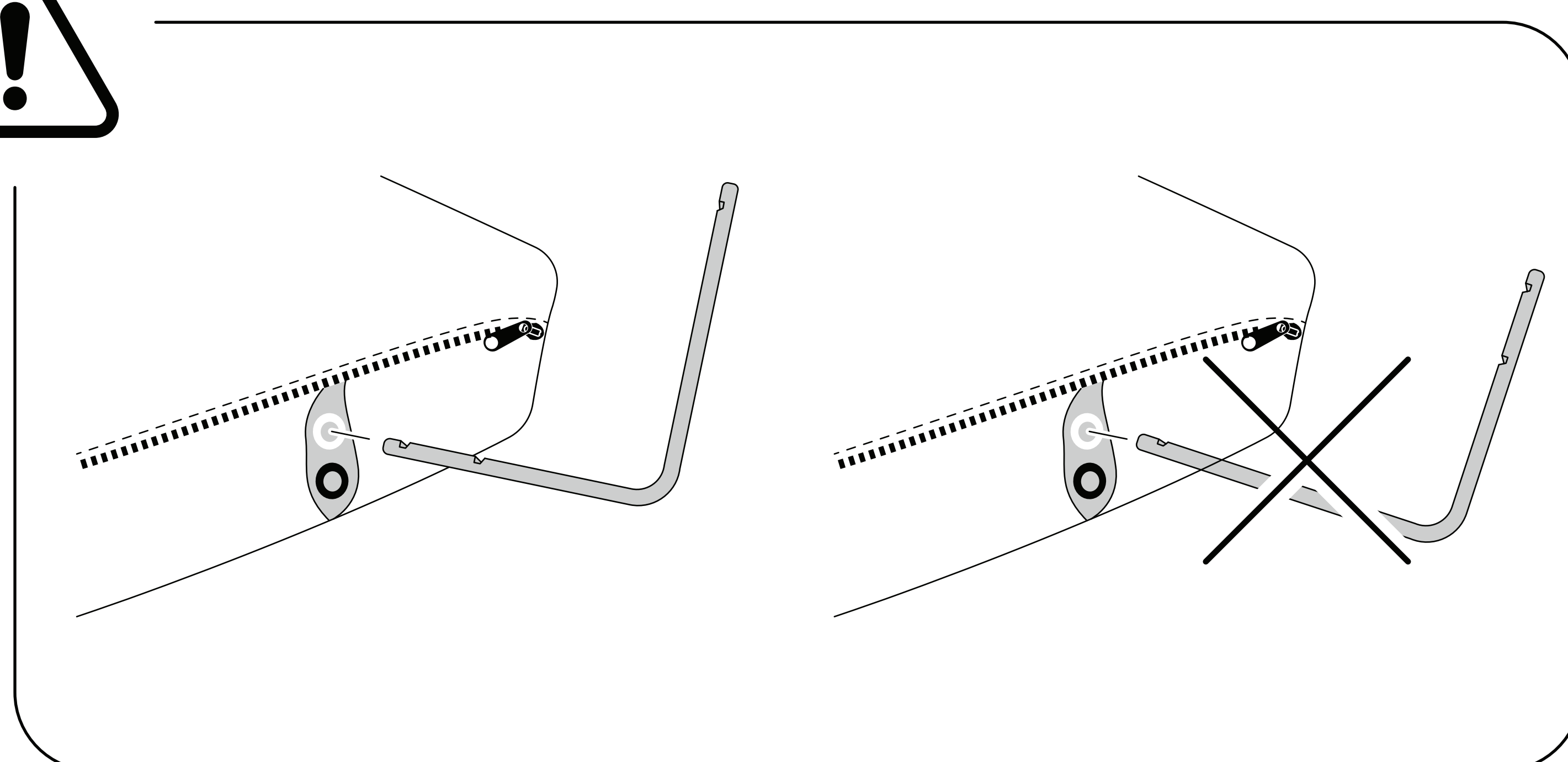
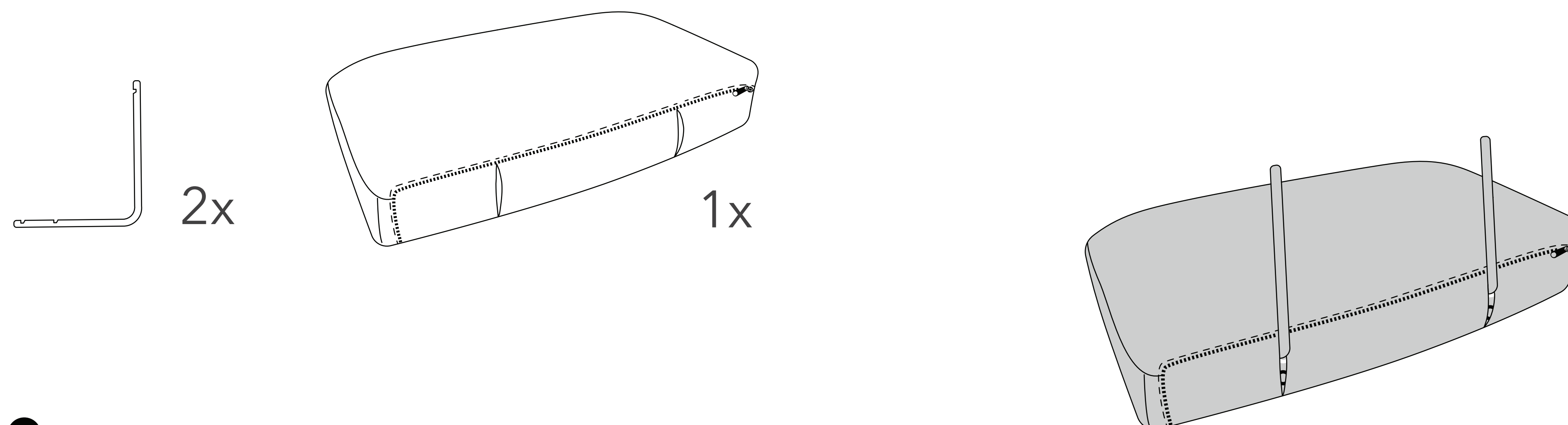

23

### Attach cushion to seat A

Insert brackets into seat. Listen for the clicks.

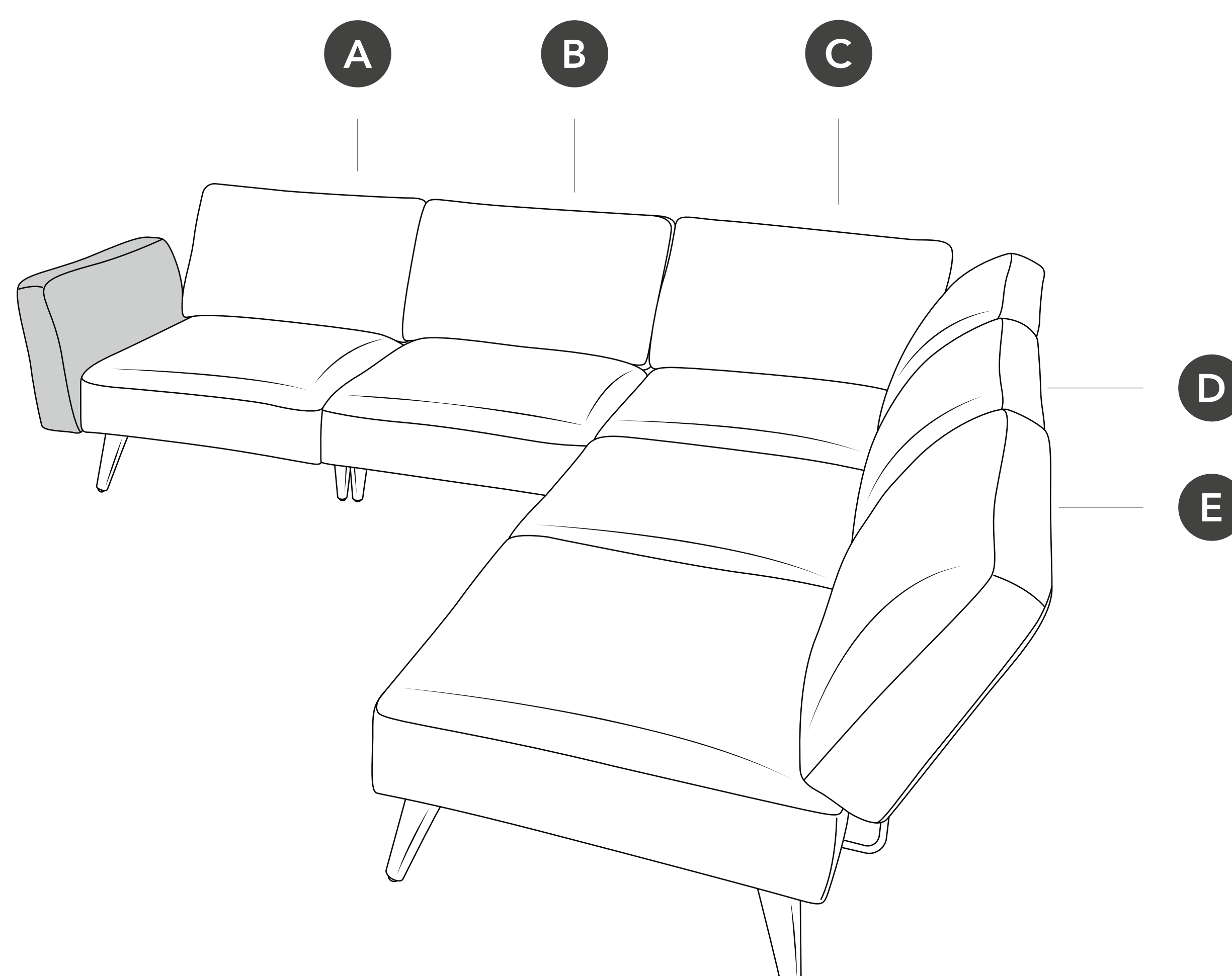
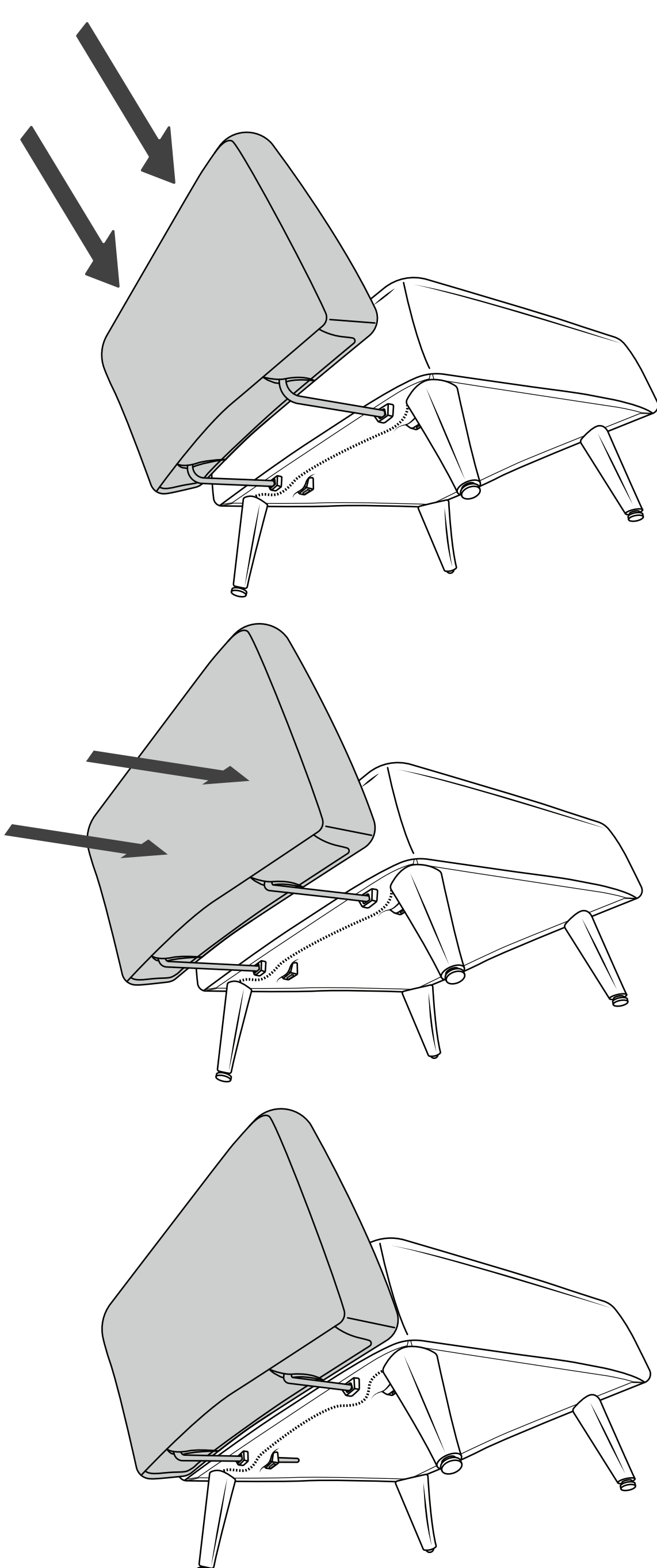

**24** Attach cushion to seat E

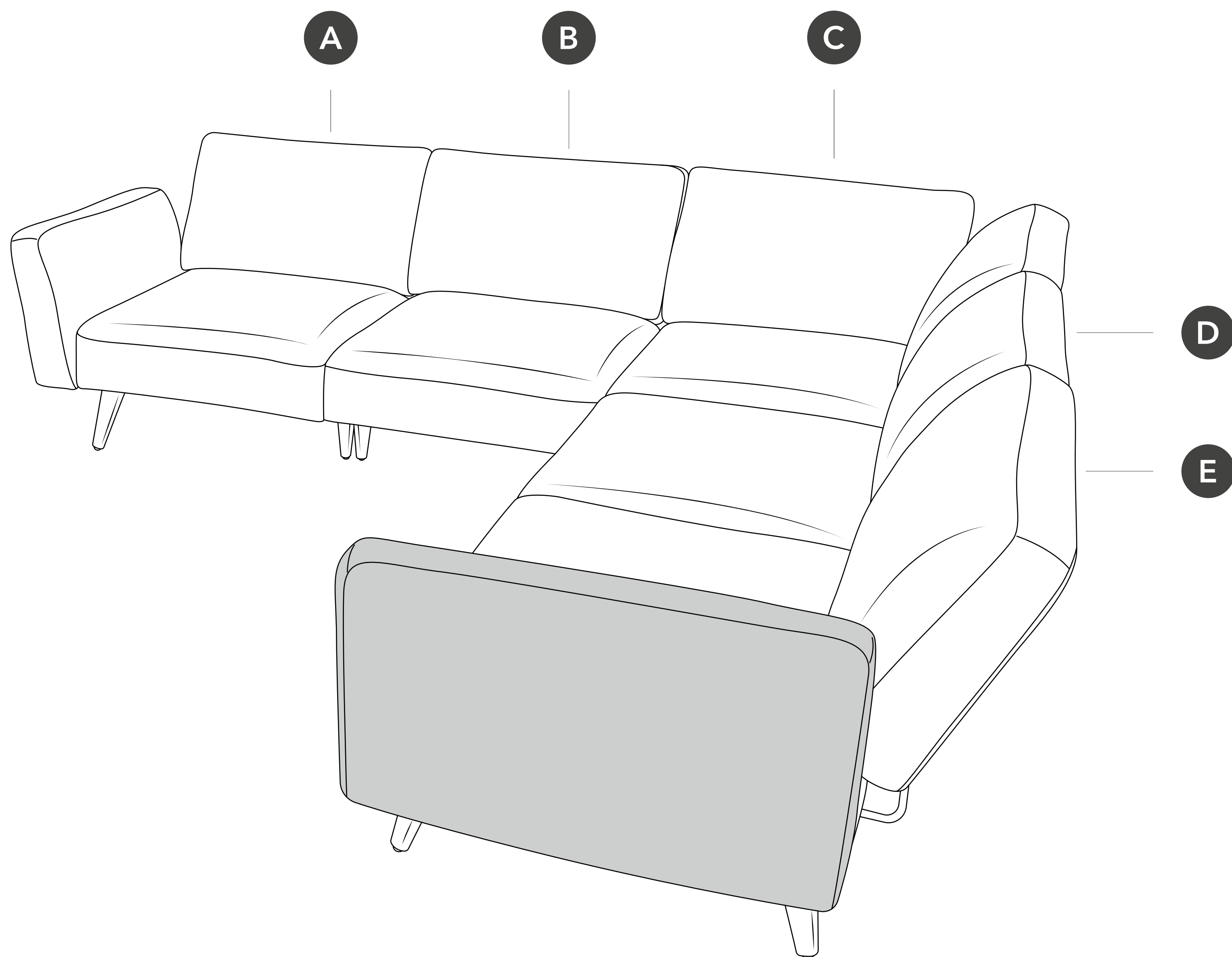

**25** Enjoy

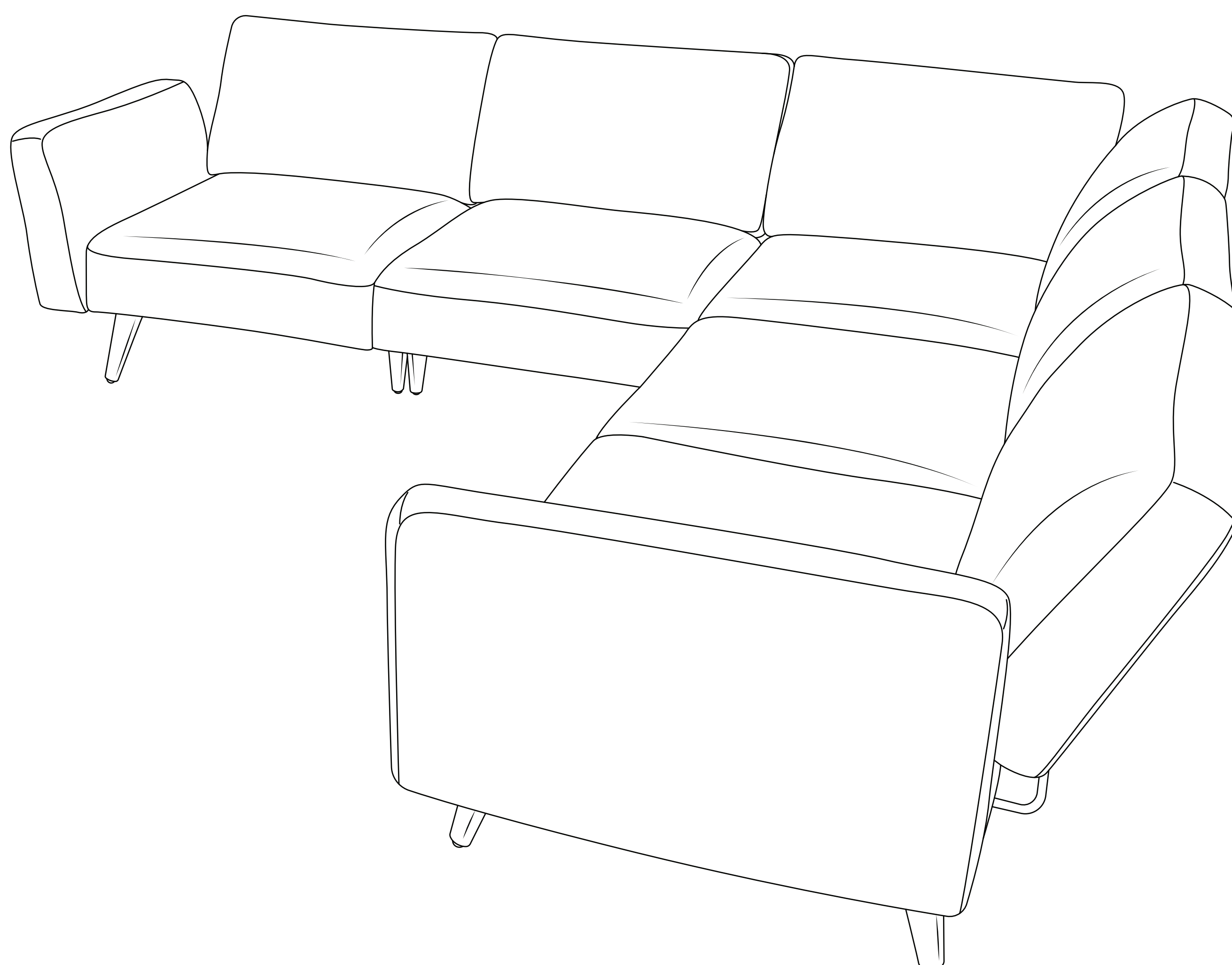

We're here to help

For help and support contact us live on chat or email us at [support@wattleliving.com](mailto:support@wattleliving.com)